

INSTRUCTIONS FOR OPERATING  
THE NRI PROFESSIONAL SIGNAL GENERATOR  
MODEL 88

NATIONAL RADIO INSTITUTE  
16TH AND U STS., N. W.  
WASHINGTON 9, D. C.

# HOW TO USE THE MODEL 88 NRI PROFESSIONAL SIGNAL GENERATOR

## Introduction

Your Model 88 Signal Generator is a complete and modern servicing instrument, designed to meet the requirements of full-time and spare-time professional radio servicemen.

Close cooperation between NRI engineers and those of the manufacturer during months of design and experimental work has made this instrument one of the finest in its class. We are proud of its appearance, its design, its ruggedness and performance. Once you get acquainted with your signal generator and learn how to use it properly, you will be proud to have it on your workbench and to have it displayed so that customers may see it. You have an exclusive, custom-built instrument which is available only to NRI men.

The NRI Signal Generator has been designed with two purposes in mind. First, it is one of the basic instruments needed for professional radio work. Secondly, it can be used to good advantage in carrying out the NRI practical training plan. This training plan, which is outlined in the NRI Course, enables you to secure practical radio experience right in your own home within a short time. The signal generator has been designed as a companion instrument for the other fine test equipment in the NRI line and can be used to good advantage with them.

With the Model 88 Signal Generator, you can follow professional servicing techniques when aligning a set and when locating defective sections or stages. It is useful in servicing all types of receivers. The communications expert will find this instrument useful for checking some parts of broadcast, short-wave and Television transmitters. Electronic engineers, public address specialists, facsimile experts and coin-operated phonograph technicians will find scores of uses for this excellent signal generator.

Once you have unpacked your signal generator, you will see that it appears as in Fig. 1. The schematic diagram is shown in Fig. 2. A conventional a.c.

full-wave rectifier type power supply is used. V3 is the rectifier tube.

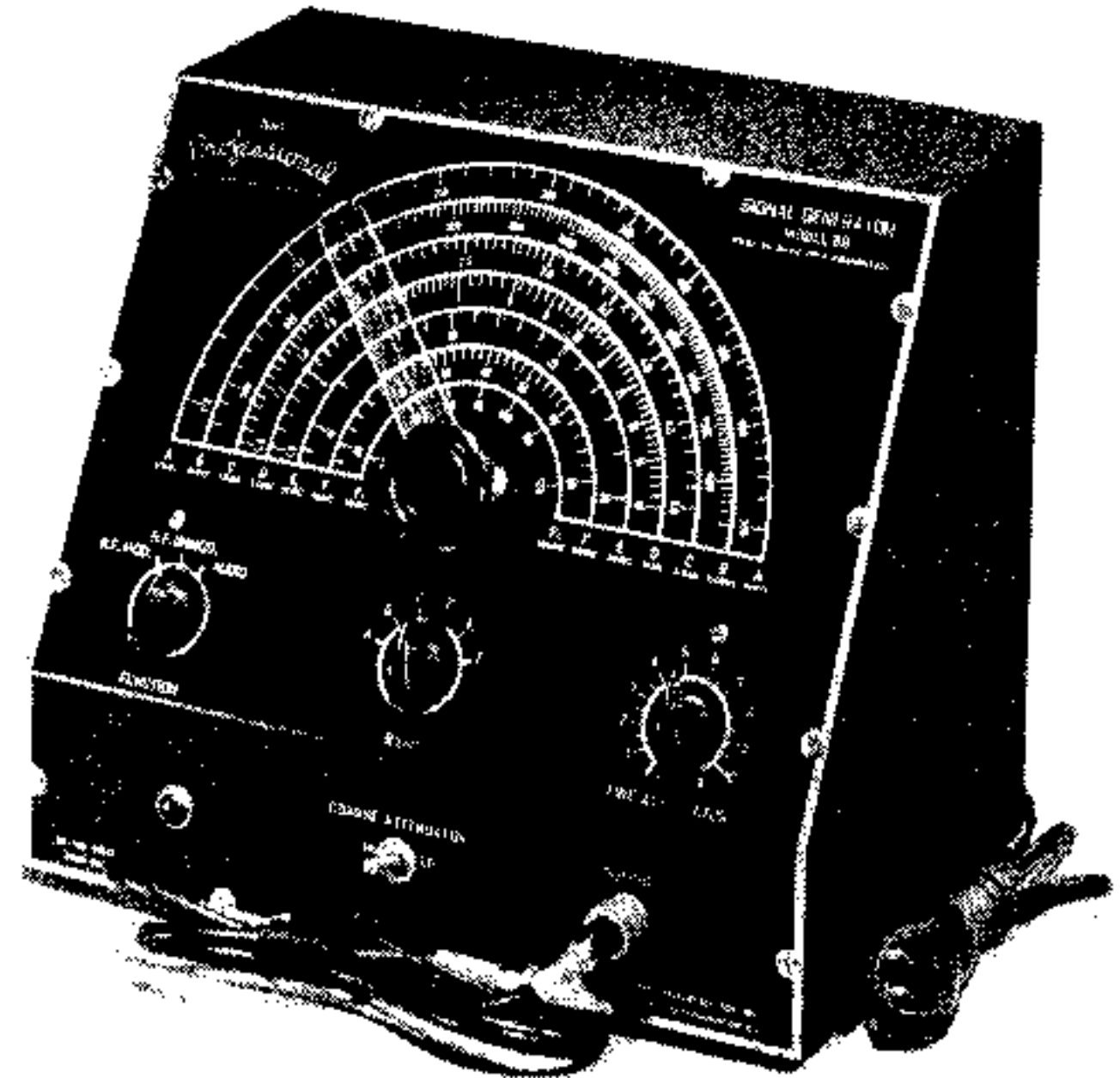

FIGURE 1  
The Model 88 NRI Professional Signal Generator.

After you have looked the signal generator over, you will naturally feel a strong desire to try it out. We can hardly blame you for wanting to see how the signal generator works. However, you must remember that the signal generator is a precision test instrument. We strongly urge you to read this instruction book carefully before trying it out. A step-by-step study of this book, combined with the actual use of your NRI signal generator after each step, will give you excellent training in the proper use of this instrument.

Let us emphasize an important point. This instrument is designed for use only on 110-120 volt, 50-60 cycle a.c. power. DO NOT use this signal generator on any but the specified power. DO NOT attempt to use the signal generator on 25 cycle power or d.c. power. SERIOUS DAMAGE TO THE INSTRUMENT WILL RESULT.

## USE OF CONTROLS

Fig. 3 shows a view of the front panel of the instrument. Let us identify the controls.

In the center of the front panel and

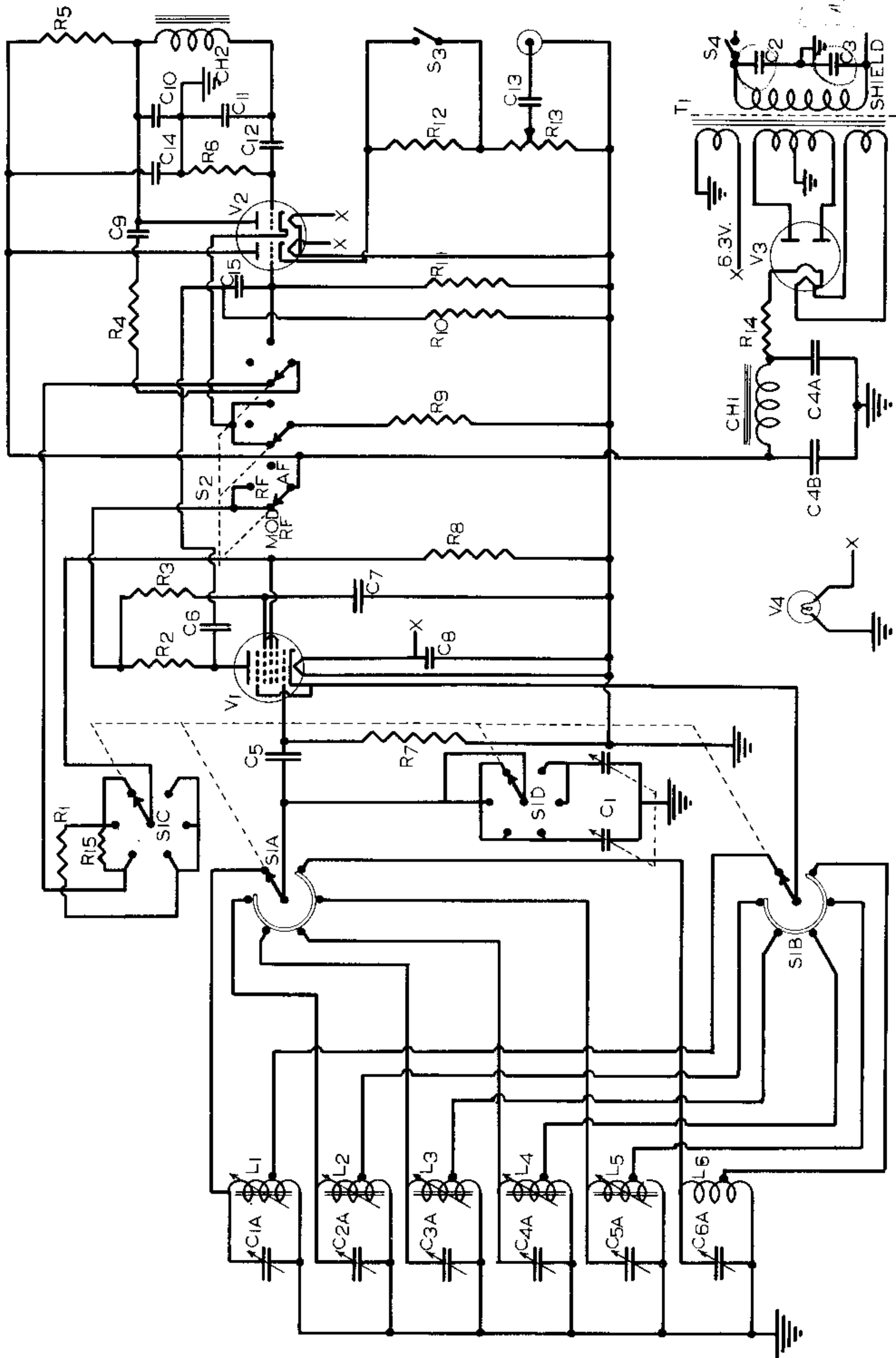

PART NO.	COILS	PART NO.	RESISTORS	PART NO.	SMITCHES
L1	A Band 170 Kc to 500 Kc Inductance Tuned	R1, R15	200 K	S1	Sections A & B, 6 Position, 2 Circuit Band (Shorting)
L2	B Band 500 Kc to 1500 Kc "	R2	5 K	S2	Sections C & D, 6 Position, 2 Circuit Band (Non-Shorting)
L3	C Band 1.5 Mc to 4.5 Mc "	R3	15 K - 1 Watt	S3	3 Pole, 3 Position Rotary
L4	D Band 4.5 Mc to 13.5 Mc "	R5, R8	100 K	S4	SPST Toggle
L5	E Band 13.5 Mc to 30 Mc "	R6	62 K		"On-Off" on R13
L6	F Band 30 Mc to 60 Mc Air Core	R7	20 K	PART NO.	TUBES, Etc.
		R9	3600 Ohms	V1	6BE6
		R10	5 K	V2	6SN7
		R4, R11	300 K	V3	5Y3 or 5Z4
		R12	100 K	V4	6.3 Pilot Light
		R13	3 K Carbon Potentiometer	T1	Power Transformer
		R14	2200 Ohms, 1 watt		
		PART NO.	CHOKES		
		CH1	Filter Choke 40 Ma., 4.5 henries		
		CH2	AF Oscillator Choke 4.5 henries		
PART NO.	CONDENSERS				
C1A thru C6A	3 to 30 mmfd Trimmers				
C1	Two Section Gang Condenser 450 mmfd x 75/85 mmfd				
C2, C3, C7, C8	.015 mfd				
C4	10 x 10 mmfd 450 V Electrolytic				
C5	50 mmfd				
C6, C15	50 mmfd				
C9	.01 mfd				
C10, C11	.05 mfd				
C12	.04 mfd				
C13	.1 mfd				
C14	.015 mfd				

above the other controls you will see a large knob with a clear plastic pointer attached. This is the main tuning control for fine adjustment of the frequency. It corresponds to the tuning control in a conventional receiver.

Below the main tuning control are three bar knobs mounted in a row. The control on the left is the three position "FUNCTION" selector switch. The center control is the six position "BAND" Selector switch. The control on the right is the "FINE ATTENUATOR" control. (The "on-off" switch is also incorporated in this control.)

Beneath these controls, on the vertical section of the panel, are three other items of interest. At the left is the pilot lamp jewel. In the center is the "COARSE ATTENUATOR" switch which is used to obtain a "high" or "low" output signal as desired. On the right is the "OUTPUT" jack. The output cable is connected to this jack with a screw cap connector.

Let us discuss the operation of each control in turn.

**MAIN TUNING CONTROL:** This control is used to vary the frequency of the r.f. signal generator over a given band. A "vernier" type of tuning arrangement is provided so that an accurate frequency setting may easily be obtained.

**FUNCTION CONTROL:** This is used to select one of three types of output signal: (1) a modulated r.f. signal; (2) an unmodulated r.f. signal; or (3) an audio signal. Any of these three types of output are available at the "OUTPUT" jack by changing the position of this switch.

**BAND SWITCH:** This is used to select the band of frequencies desired. It has six positions: A, B, C, D, E, and F, corresponding to frequency scales on the main tuning dial. Notice that a frequency scale is calibrated for use of the second harmonic of band "F." When reading frequency scale "F1," the BAND switch should be in the "F" band position. The bands cover frequencies as follows:

- Band A: 170 kc. to 550 kc.
- Band B: 550 kc. to 1600 kc.
- Band C: 1.6 mc. to 5.0 mc.
- Band D: 4.5 mc. to 15 mc.
- Band E: 15 mc. to 30 mc.

Band F: 30 mc. to 60 mc.  
 Band F<sub>1</sub>: 60 mc. to 120 mc.  
 (second harmonic of band F)

FINE ATTENUATOR: The FINE ATTENUATOR consists of a continuously variable output control. It is used to give a

clockwise until the "click" is heard, and the power cord is plugged in, the pilot lamp jewel should glow, indicating the instrument is turned on.)

COARSE ATTENUATOR: This is a toggle switch used to switch a resistor in

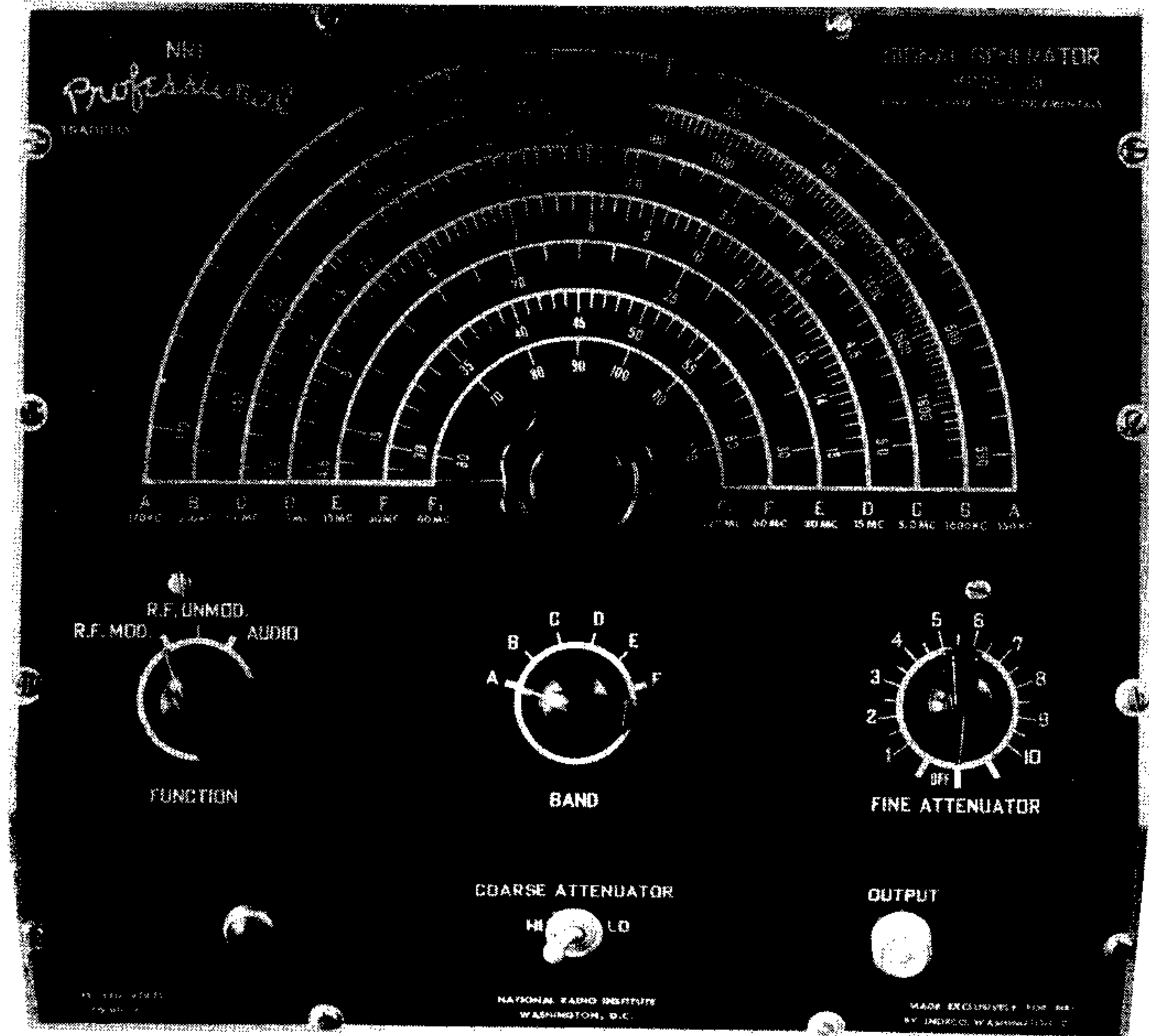

FIGURE 3  
 Controls on panel of Model 88.

close or "fine" adjustment of the output signal intensity or strength. To increase the output of the signal generator, turn this control in a clockwise direction. As you turn the control clockwise from the "OFF" position you will hear a slight "click." This indicates that the instrument is "ON." (When the control is turned

and out of the circuit so that the strength of the output signal may be varied over quite a wide range. It has two positions, a "HI" and a "LO" position. In the "HI" position, a much stronger output signal is obtained than in the "LO" position.

OUTPUT JACK: This is simply a screw

type connector jack to which the coaxial output cable is connected.

#### How to Set the MAIN TUNING CONTROL to Desired Frequency

The main tuning dial consists of seven scales, labeled at each end with letters A, B, C, etc., thru F<sub>1</sub>. Each scale is calibrated to cover a given band of frequencies. For example, when the BAND switch is set at position "A," readings are made on scale "A" of the main tuning dial. Note that scales A and B read in kilocycles (thousands of cycles) while the other scales (C, D, E, F, F<sub>1</sub>), all read in megacycles (millions of cycles).

As an aid in selecting the correct setting of the BAND switch, the lowest and highest frequency covered by each band is indicated at the extreme ends of each corresponding scale on the main tuning dial. Example: Beneath the left end of scale A is printed "170 kc." Beneath the right end of scale A is printed "550 kc." Therefore, if any frequency between 170 kc. and 550 kc. is desired, the BAND switch is set to position "A." The main tuning control is then turned so that the red "hairline" in the plastic pointer is directly over the desired frequency on scale A.

If a frequency of 1400 kc. were needed for aligning a receiver, what position of the BAND switch would be used? Referring to the main dial scales, we see the maximum frequency covered by Band "B" is 1600 kc. and the minimum frequency covered by Band "B" is 550 kc. Since 1400 kc. falls between these limits, the BAND switch will be set at position "B." The "hairline" of the main tuning control is then set at 1400 kc. on scale "B." (It is worthwhile noting here that Band "B" covers the A.M. broadcast band of frequencies.)

Where the desired frequency is directly calibrated on the dial, then the transparent pointer is moved over the dial until the red "hairline" is directly over the long marker line representing that frequency.

If the signal generator is to be set to a frequency not directly calibrated on a given scale, then the short lines

between the longer marker lines are used. For intermediate readings, an estimation is made between the short lines.

The value represented by each division (short line) between calibrated or marker lines for the different bands is given below:

For Band A: each division represents 10 kilocycles.

For Band B: each division represents 10 kilocycles.

On Band C: (from 1.6 megacycles to 2.0 megacycles) each division represents .02 megacycles or 20 kilocycles; (from 2.0 to 3.0 megacycles) each division represents .05 megacycles or 50 kilocycles - two such divisions representing .1 megacycle; (from 3.0 to 5.0 megacycles) each division represents .1 megacycle or 100 kilocycles.

On Band D: (from 4.5 to 7 megacycles) each division represents .1 megacycle or 100 kilocycles; (from 7 to 15 megacycles) each division represents .2 megacycles or 200 kilocycles.

On Band E: each division represents 1 megacycle.

On Band F: each division represents 1 megacycle.

On Scale F<sub>1</sub>: each division represents 10 megacycles; however, the intermediate markers on Scale F may be used to indicate divisions of 2 megacycles when reading the F<sub>1</sub> scale.

In order to speed up the dial setting of the signal generator when aligning the i.f. transformers of superheterodyne receivers, the 3 most common i.f.'s are spotted on scale A. These are represented by small dots on the scale. They are located at frequencies of 175 kilocycles, 455 kilocycles, and 465 kilocycles. (The marker dot for 455 kilocycles can be used when aligning i.f. transformers to either 455 or 456 kc.)

You can see these dots quite easily. Refer to the "A" scale on the main dial of your signal generator. The 175 kc. marker dot is located halfway between 170 kc. and the next small unmarked line (180 kc.) The 455 kc. marker dot is found between the line calibrated to read 450 kc. and the next unmarked line (460 kc.). Between the unmarked line

representing 460 kc. and the unmarked line representing 470 kc., there is the marker spotting the frequency of 465 kc. This marking of the i.f.'s will speed up alignment of superhets considerably.

Avoid Parallax Error: When setting the plastic pointer to a given frequency, be sure that you are looking directly toward the pointer and dial scales. If your eyes are not squarely in front of the pointer, an error in reading the scales (called parallax error), will result. Be especially careful about this when placing the signal generator at one side of the receiver under test, as there is then a tendency to read the dial from an angle.

Examples which will help you learn to read various settings on the signal generator scales are given in Fig. 4.

Just assume that the white lines X, Y, and Z represent different dial pointer positions. Write down what you think the frequency reading is on each band for each of the three pointer positions. Compare your readings with those given on page 28, and try to analyze any discrepancies which may occur.

#### Use of Shielded Coaxial Output Cable

If ordinary test leads, like those used in making voltage or ohmmeter tests, were used to connect your signal generator to a receiver, the leads might pick up stray fields, causing interference, and would also radiate r.f. energy. Remember that the signal generator acts as a miniature radio transmitter - the leads would then act as an antenna. Various

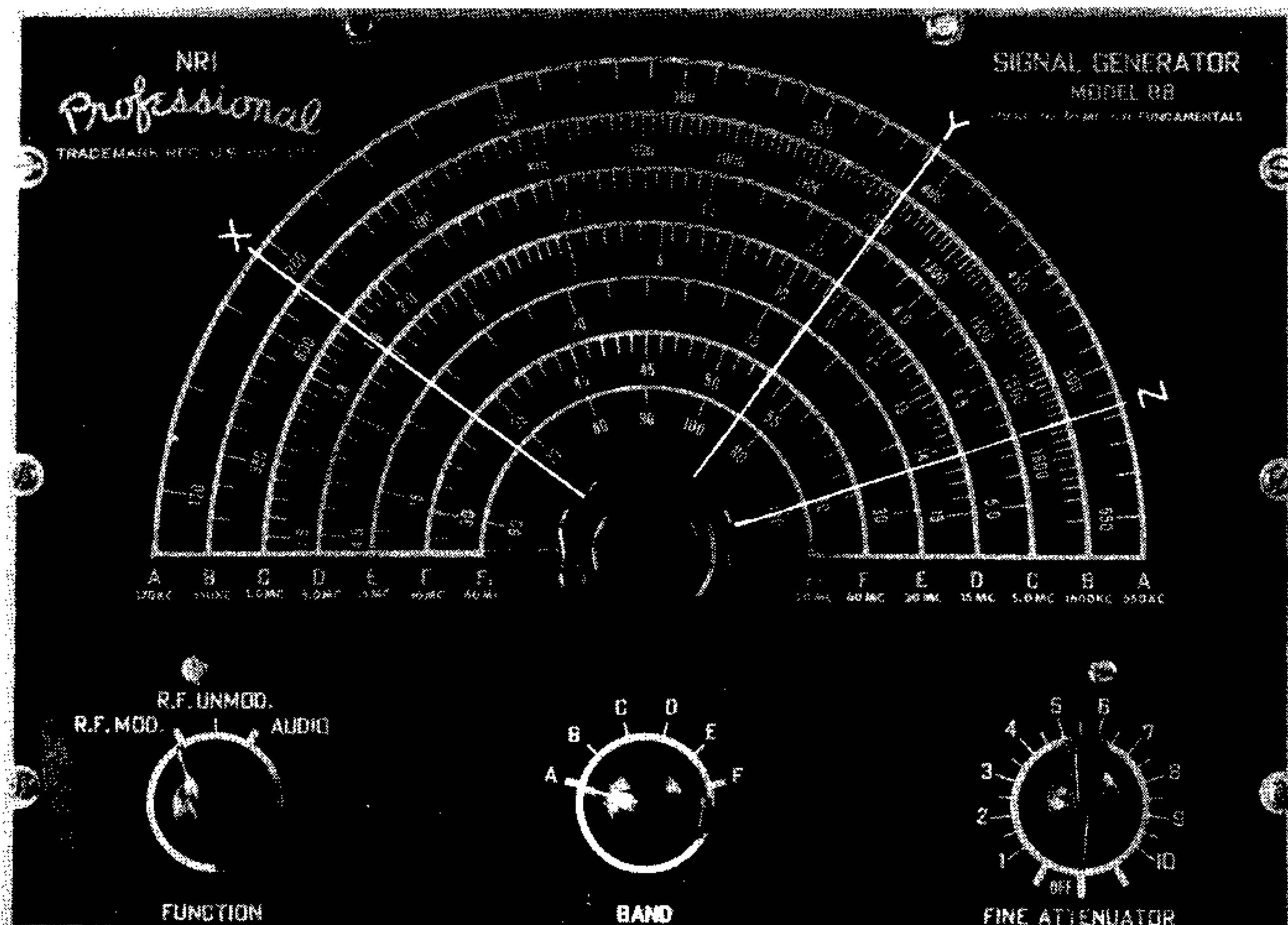

FIGURE 4

A reproduction of the dial scales on the Model 88. Lines X, Y, and Z represent three possible frequency settings. To secure experience in reading the frequency scales, record what you think the frequency settings are on each band, for each pointer setting. Compare them with the correct readings, as given on page 28.

used in the set, you should note some change here.

Once you have seen how the "COARSE ATTENUATOR" control works, turn it to the "HI" position and gradually turn the "FINE ATTENUATOR" counterclockwise. Again you should notice a reduction in the intensity of the signal.

Repeat this general procedure for a number of different frequencies and on different bands if you wish. If you go to higher frequency bands on the signal generator, it is necessary that you have short-wave bands in the receiver in order to pick them up.

You can also make some experiments on using harmonics of lower frequency signals so as to get familiar with the general technique.

Set the "FINE ATTENUATOR" on 10 and the "COARSE ATTENUATOR" on "HI," for maximum signal generator output. Set the "FUNCTION" switch in the "R. F. MOD." position. The "BAND" switch should be set in the "B" position.

Set the receiver at a frequency of around 1200 to 1300 kilocycles (where no local station is picked up) and slowly tune the main tuning knob of the signal generator between 550 and 700 kilocycles. You should find one point at which a signal is heard through the receiver's loudspeaker. Since the receiver is tuned to a frequency twice that of the signal generator, you are picking up the signal generator's second harmonic with the receiver.

You can experiment on picking up third harmonics of signals by simply switching the signal generator to band "A" and tuning from about 400 kilocycles to 450 kilocycles. Listen for an audio signal in the receiver's loudspeaker.

To get acquainted with the operation of your signal generator as an audio signal source, turn the "FUNCTION" switch to the "AUDIO" position. Set the "FINE ATTENUATOR" and "COARSE ATTENUATOR" controls for maximum output as outlined previously. Disregard the settings of the main tuning knob and the "BAND" switch, as the audio output is fixed at approximately 400 cycles.

If your test receiver has a connection for a phonograph, determine which is the "hot" connection point by switching

the receiver to "phono" and turning the receiver volume control to maximum. With the finger, or a screwdriver, touch the terminals where the phono connection is made. When the "hot" terminal is touched, a hum will be heard in the receiver's loudspeaker. Once you have determined which is the "hot" input terminal, clip the "hot" signal generator lead (red) to this terminal and clip the "ground" lead (black) of the signal generator to the "ground" terminal or to the set chassis.

You should now hear a loud audio note. (It may be so loud that the set is overloaded so that a distorted note is heard.) You can reduce the intensity of this note by turning back the receiver's volume control; by adjusting the position of the "COARSE ATTENUATOR" control to the "LO" position; or by turning the "FINE ATTENUATOR" counterclockwise to a lower reading.

If the receiver does not have a "phonograph" connection terminal, but the receiver employs a superheterodyne circuit and diode detector, then you can usually clip the leads from the signal generator across the receiver's volume control. Determine which is the "hot" side by turning the volume control on full and touching each outer terminal. The terminal from which the hum is heard is the "hot" side. The hot signal generator lead connects here. (The signal generator "ground" lead is then connected to the receiver's chassis, or to the ground terminal of the volume control.)

Finally, if the volume control is not in the a.f. section of the receiver, make connections directly between the grid of the first audio tube of the set and ground.

If you follow the above procedure, you will soon become familiar with the use of the various controls on your signal generator and how the manipulation of these controls affects the output of the signal generator.

#### Uses of a Signal Generator

A signal generator is used to provide known test signals of variable intensities. These test signals can be used in the following ways:

(a) Alignment: Consists of injecting



known signals into the receiver and adjusting tuned circuits in the receiver so that maximum output is obtained. Various components are adjusted, such as trimmer condensers, and "iron slugs" on permeability tuned coils, in accordance with a definite procedure. In addition to the variable frequency signal generator, an insulated alignment tool (illustrated in Fig. 5), should be used. An



FIGURE 5  
Typical Insulated Alignment Tool.

output indicator of some sort is very desirable.

(b) Stage-By-Stage Testing: Consists of injecting a known signal at given points in the receiver to see if stages following that point operate properly. The stage-by-stage testing technique is used to isolate trouble in a receiver and can be carried out by methods other than "signal injection." For example, the well-known "circuit disturbance" test used on dead receivers is a form of stage-by-stage testing.

Regardless of how the signal generator is used - whether for alignment or stage-by-stage testing, it is necessary that the signal be introduced or "injected" at some point in the receiver. The signal is introduced in either the grid-to-chassis or the plate-to-chassis circuit of a tube, or into the receiver antenna system.

#### Connecting the Signal Generator to a Receiver

Suppose we had a typical i.f. or r.f. amplifier circuit as illustrated in Fig. 6 and wished to connect the signal generator directly to the grid of this stage. The physical connections might be made in one of several ways. If single-ended tubes, in which the grid connection is brought out to a pin on the tube base, are used, the actual physical connection might

be as shown in Fig. 7.

The clips of the signal generator cable are connected directly to the

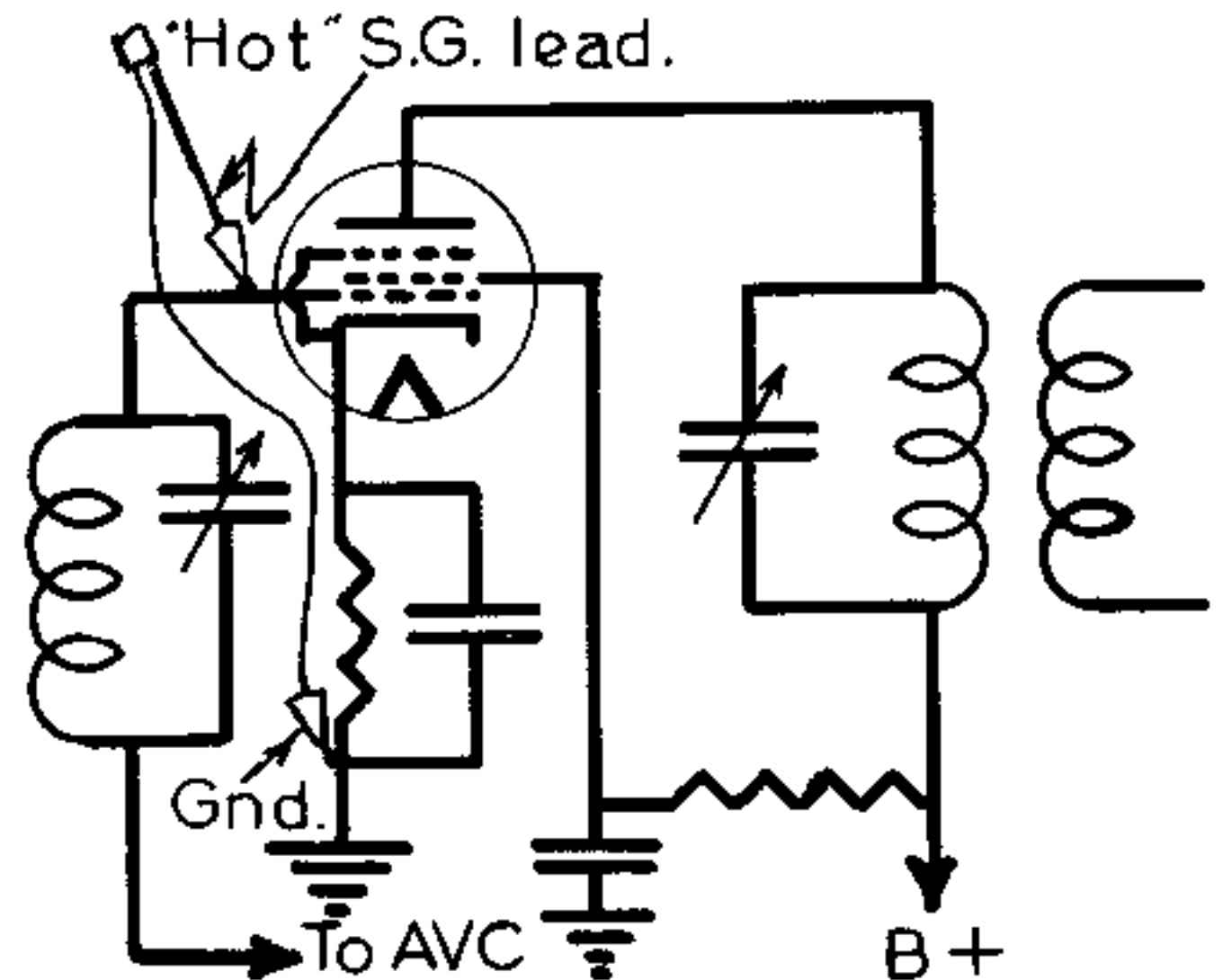

FIGURE 6  
Typical I.F. Amplifier Circuit.



FIGURE 7  
Typical connection to tube socket lugs.

socket lugs. A plate-to-ground connection might also appear similar to Fig. 7, except that the clips would clamp on different socket lugs. (You can identify the proper lugs on the tube socket by

referring to a tube chart to identify tube electrode connections from their pin positions.)

On the other hand, if the tube has a top cap, the basic schematic circuit is the same, but the connection could be made as shown in Fig. 8.



FIGURE 8

Typical connection to tube grid cap and chassis.

The "hot" lead (red) of the signal generator is connected to the grid of the tube in each case and the "ground" lead (black) is connected to the set's chassis.

When the signal generator is to be connected to the first stage in a receiver (the mixer stage or first r.f. stage in a superheterodyne or a tuned r.f. stage in a TRF type of receiver), the same type of physical connection can be made. Refer to Fig. 9 for a typical first stage in a receiver. Note that only part of the first stage is shown.

If a "single-ended" tube is used, it is not absolutely necessary to turn the set chassis over and connect directly at the tube socket terminals. You can see, from the schematic diagram in Fig. 9, that the grid connects to one section of the variable tuning condenser. This

will be to the "stator" plates. The "hot" lead of the signal generator can be clipped directly to the "stator" lug of this section of the tuning condenser, as is illustrated in Fig. 10.

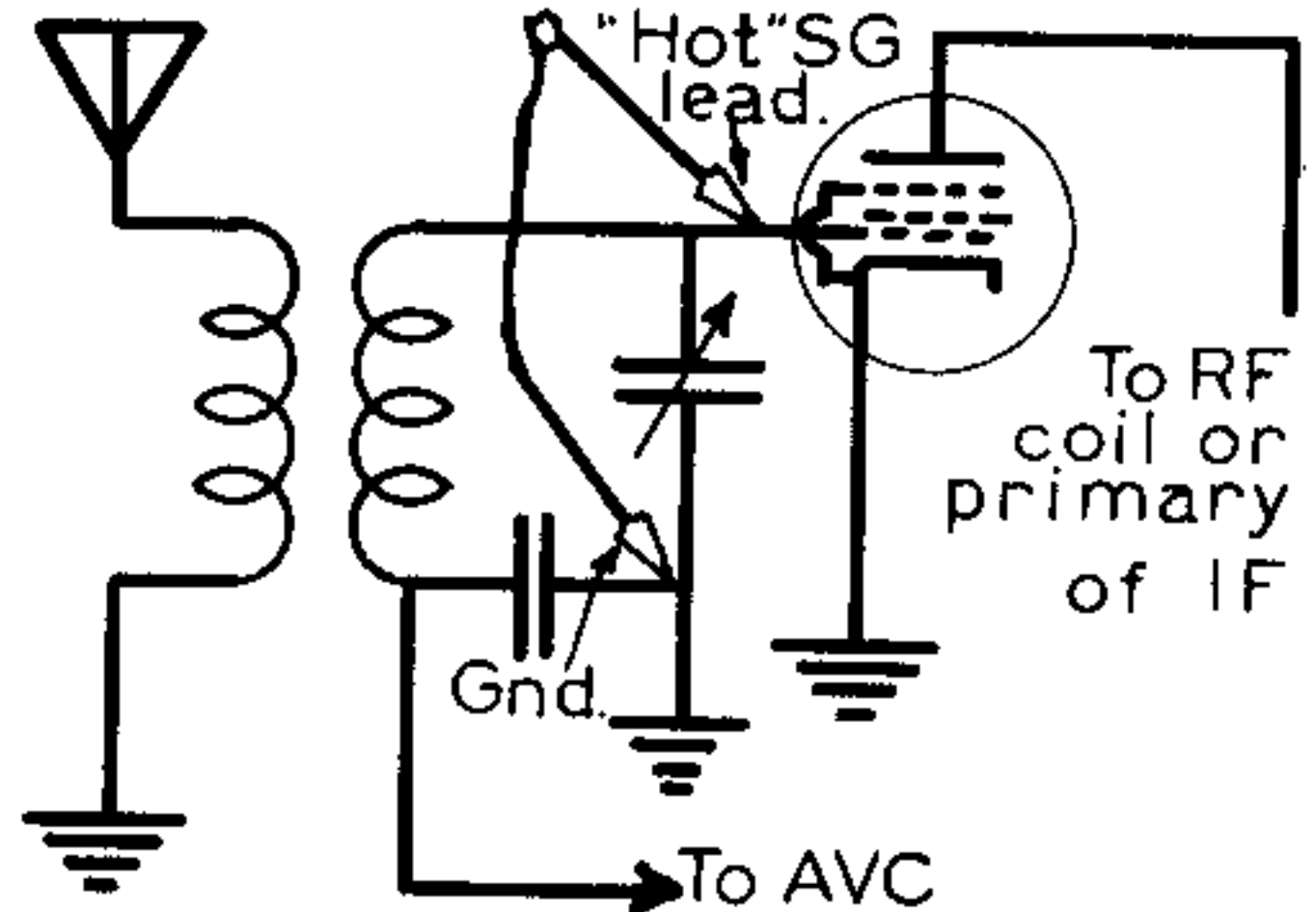

FIGURE 9

Signal Generator Connection to R. F. Amplifier or Converter Circuit.

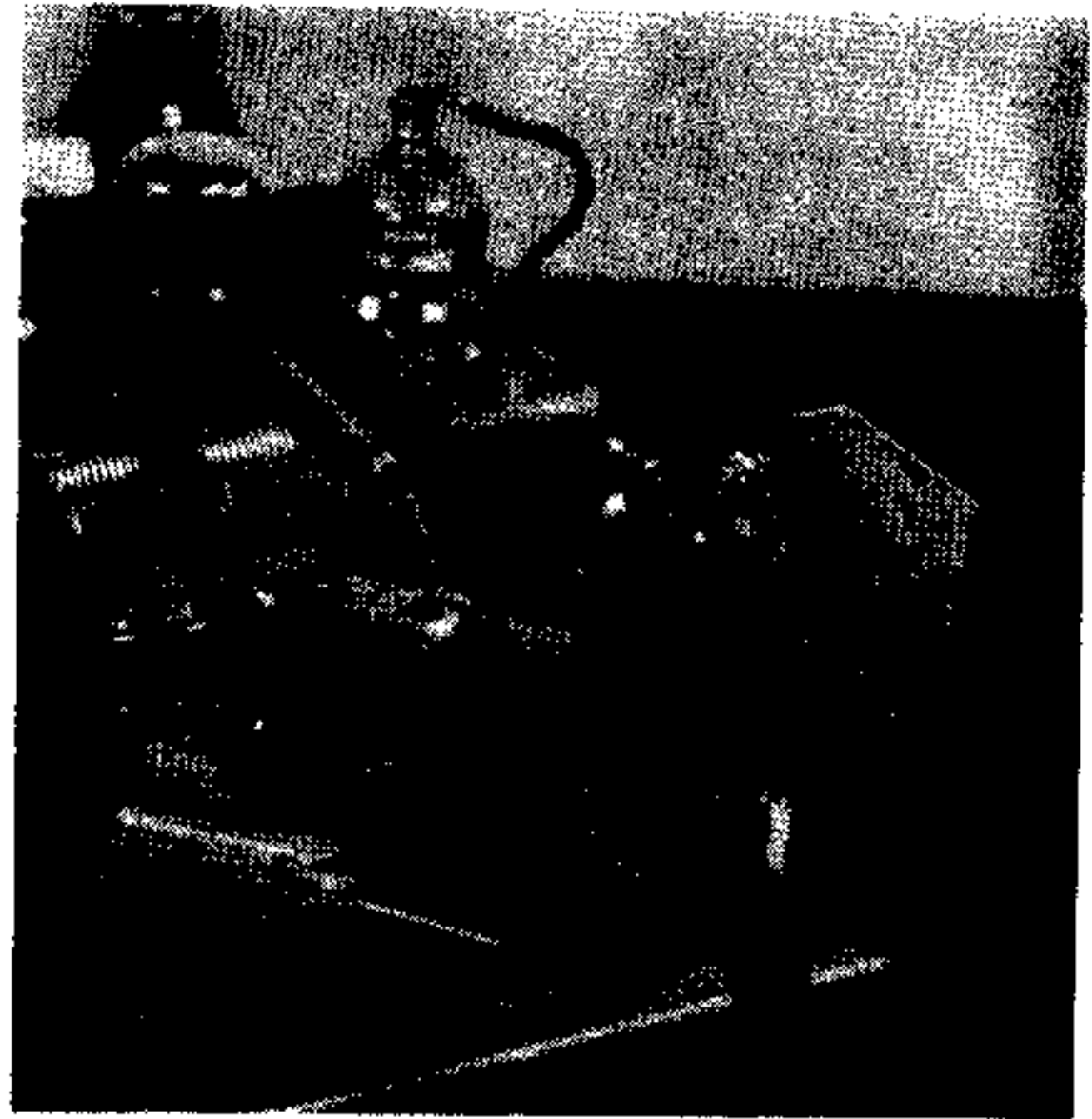

FIGURE 10

Typical connection between tuning condenser trimmer and chassis.

Where a loop antenna is used with a receiver, and it is desired to couple the output of the signal generator to this loop antenna, one of two systems might be used.

A wire may be looped loosely around the loop antenna form and connected to the signal generator leads. One end of the wire would connect to the "hot" lead and the other end of the wire would connect to the "ground" lead of the signal generator cable. This is illustrated in Fig. 11. If the set is fairly well aligned so that it has some sensitivity, a looser type of coupling may be employed as illustrated in Fig. 12. In this system, the

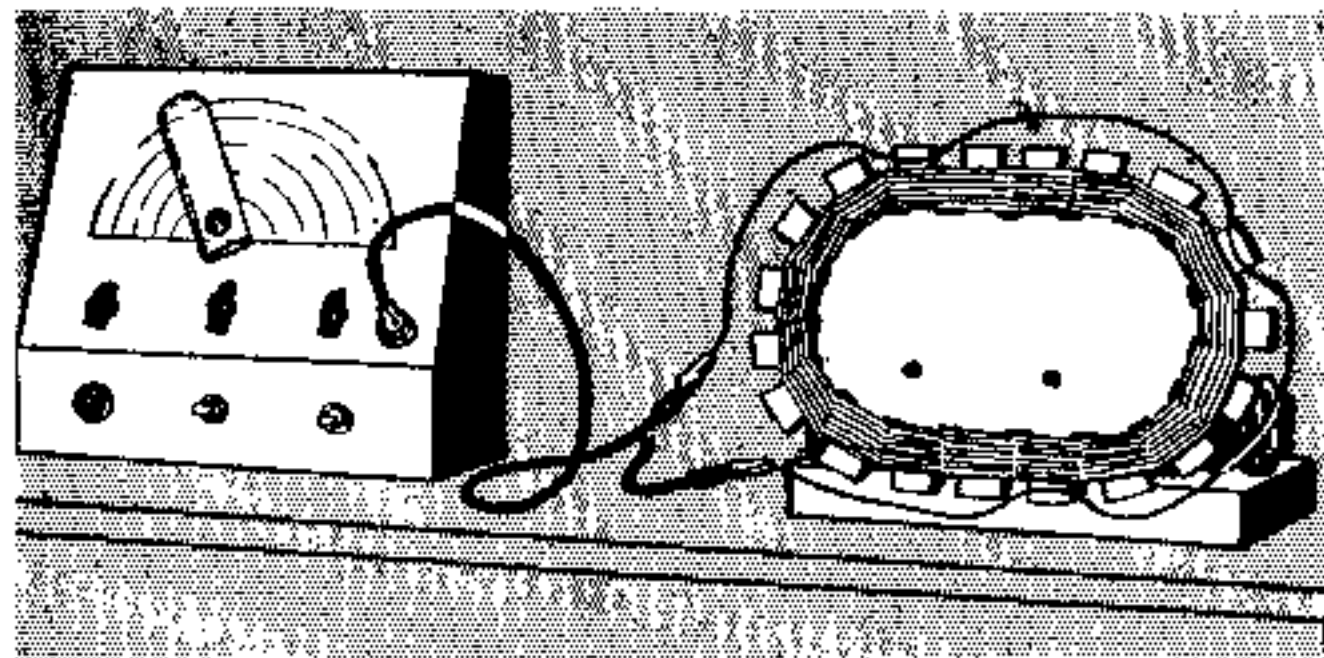

FIGURE 11

A wire looped loosely once around the loop-antenna form and connected to the signal generator leads will provide sufficient coupling for your signal generator signal.

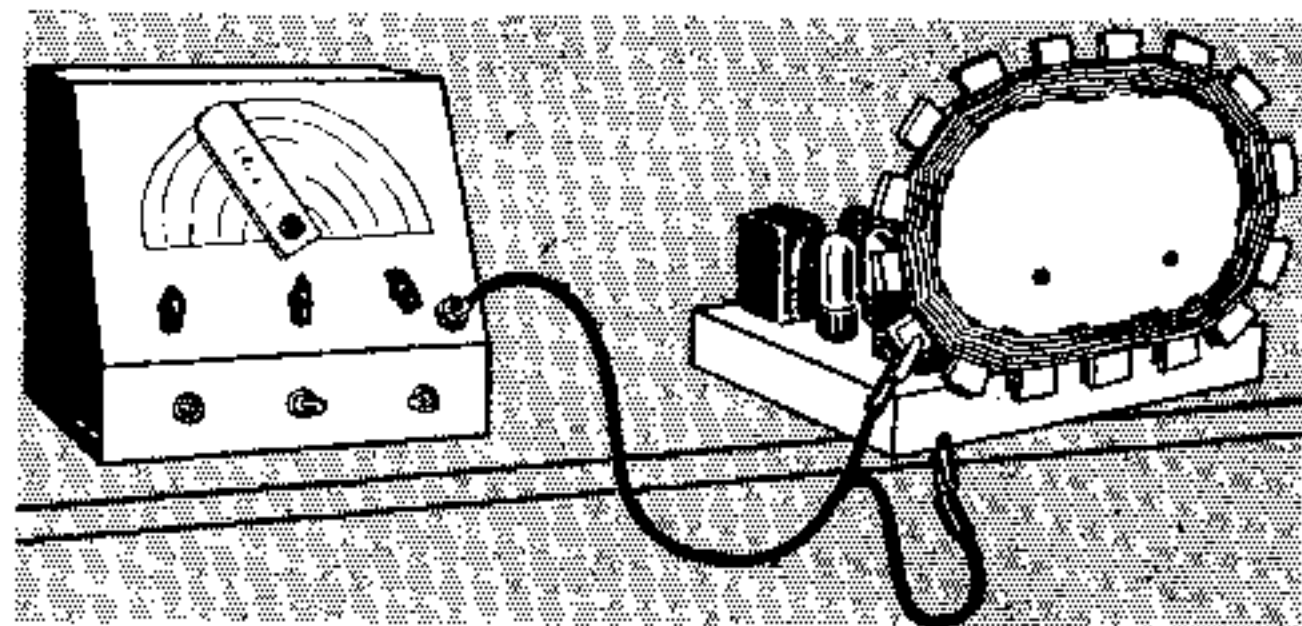

FIGURE 12

Clipping the hot signal generator lead to the loop-antenna form is another way to feed a signal into the set. Clip the signal generator ground lead to the set chassis.

"hot" lead is simply clipped to the loop antenna form and the "ground" lead is clipped to the set chassis.

Where no loop-antenna is used, and it is desired to couple to the input of a receiver, several systems may be used. You may simply clip the "hot" lead to the receiver's antenna and the "ground" lead to the receiver's ground post or chassis.

For less coupling, you may connect a short insulated wire to the antenna post of the set and clip the signal generator "hot" lead to this wire, over the insulation, so that direct contact is not made. For still less coupling, you may simply lay the signal generator lead close to the antenna wire of the receiver.

When using the signal generator to "inject" an audio signal in an audio stage, connections can be made in a similar manner. A connection between the grid and chassis in a typical first audio amplifier stage, see Fig. 13, might be

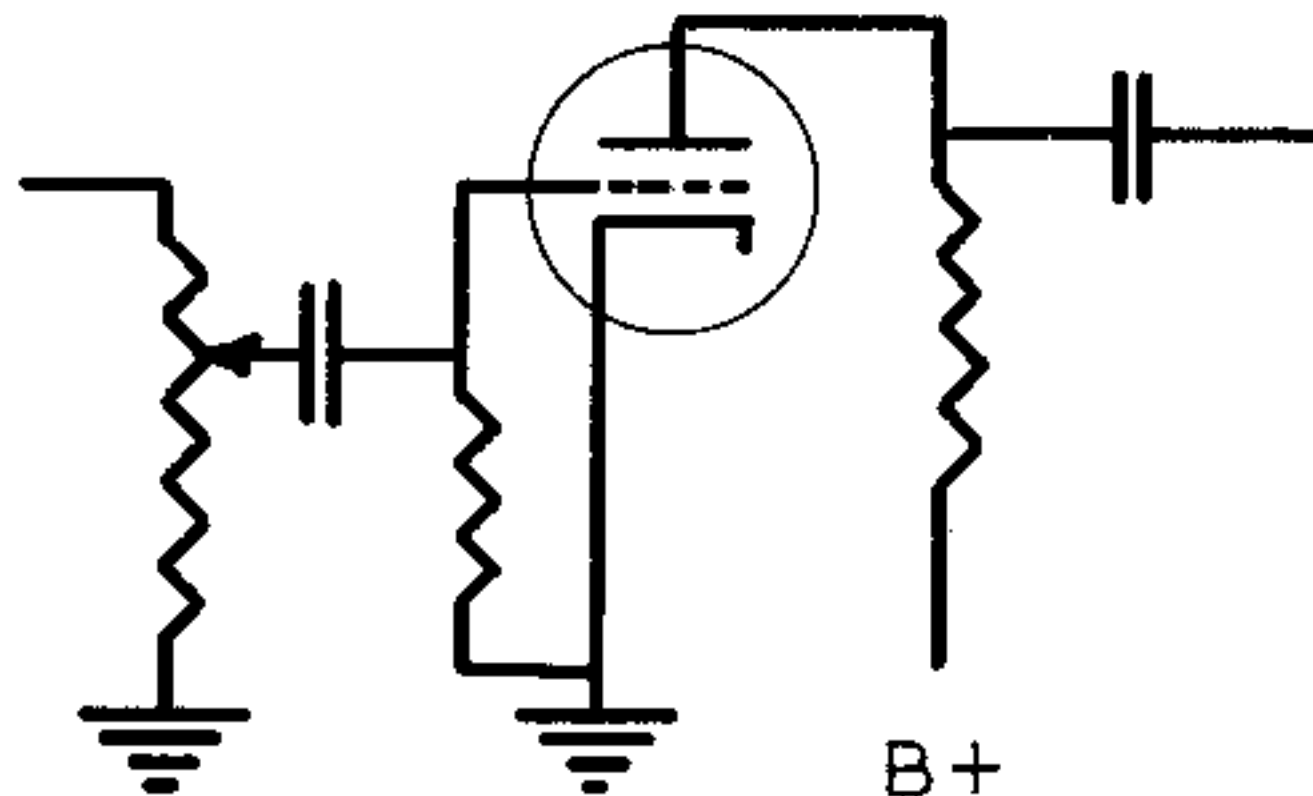

FIGURE 13

Typical first audio amplifier stage.

made by clipping the signal generator leads directly to the tube's grid and cathode socket lugs. The connections might be made between grid and ground (chassis), grid and B-, or the two leads can be clipped directly across the grid resistor of that stage.

A connection can be made directly across the volume control, using the two outer terminals of the volume control. (Be sure that you do not connect the leads to the "on-off" switch on the back of some volume controls.) This connection directly to the volume control for checking audio stages in a receiver should be made only where the volume control is used in the audio stages - usually between the second detector and the first audio amplifier. Where some other type of volume control is used, the connections can be made directly to the grid of the first audio amplifier tube.

#### Dummy Antennas

The purpose of a dummy antenna is

to simulate or create the effects of an actual antenna on the preselector or input tuned circuit. Manufacturers often recommend a particular type of "dummy antenna" which is to be connected in series with the "hot" lead of the signal generator and the receiver antenna binding post.

Some manufacturers will also recommend the use of a condenser in series with the signal generator lead when aligning the i.f. portions of a receiver. This is to isolate d.c. receiver supply voltages from the signal generator. However, a series blocking condenser is built in the hot side of the Model 88 output circuit and an additional blocking condenser is normally unnecessary.

The standard "dummy antenna" as recommended by RMA (Radio Manufacturers Association), is illustrated in Fig. 14.

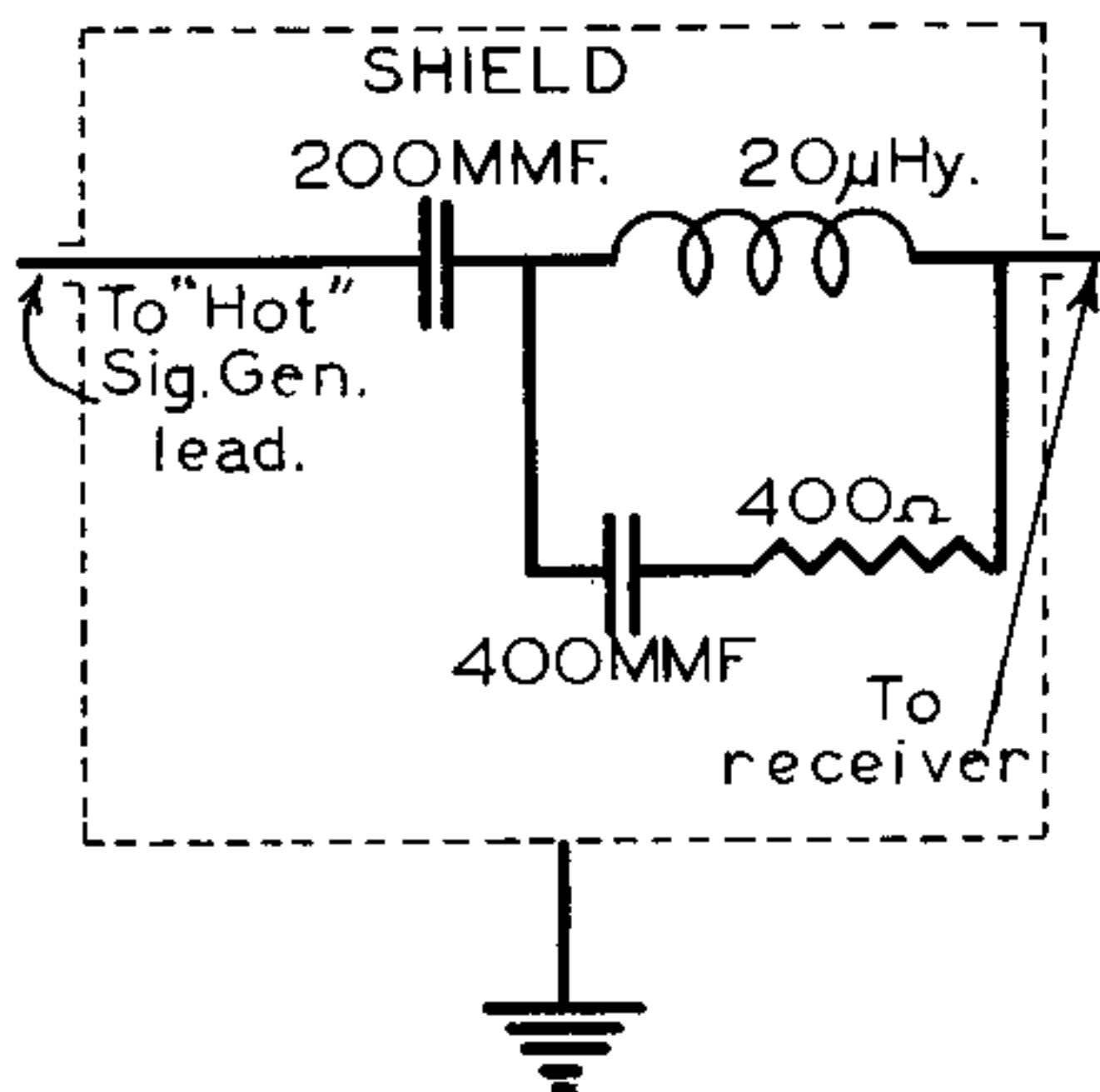

FIGURE 14  
Standard "Dummy Antenna."

Many manufacturers simply suggest using a 400 ohm resistor in place of such an elaborate dummy antenna, while others suggest the use of either a .1 or .5 mfd. condenser or a combination of resistor and a condenser.

It is felt that a dummy antenna need not be used when connecting the signal generator to a receiver, except where laboratory measurements are being taken.

Instead, we recommend that the preliminary alignment be carried out without a dummy antenna and that the final alignment of the preselector circuit be carried out in the customer's home, using a broadcast station as a signal source and using the customer's own antenna. By doing this, the best alignment can be attained. In many cases, it may be found that little, if any, adjustment need be made in the customer's home. Naturally, where a loop antenna is used, no further adjustment is necessary.

### Output Indicators

When aligning a receiver, it is desirable to connect an instrument to the receiver so that a visual indication of receiver output can be obtained when the set's adjustments are properly peaked.

When aligning TRF receivers and conventional superheterodynes, a multimeter (such as the NRI Professional Model 44) might be used as an indicator. If it is to be used as an output meter, it may be connected between the plate of a single-ended output stage and ground as shown in Fig. 15, or between one side of a

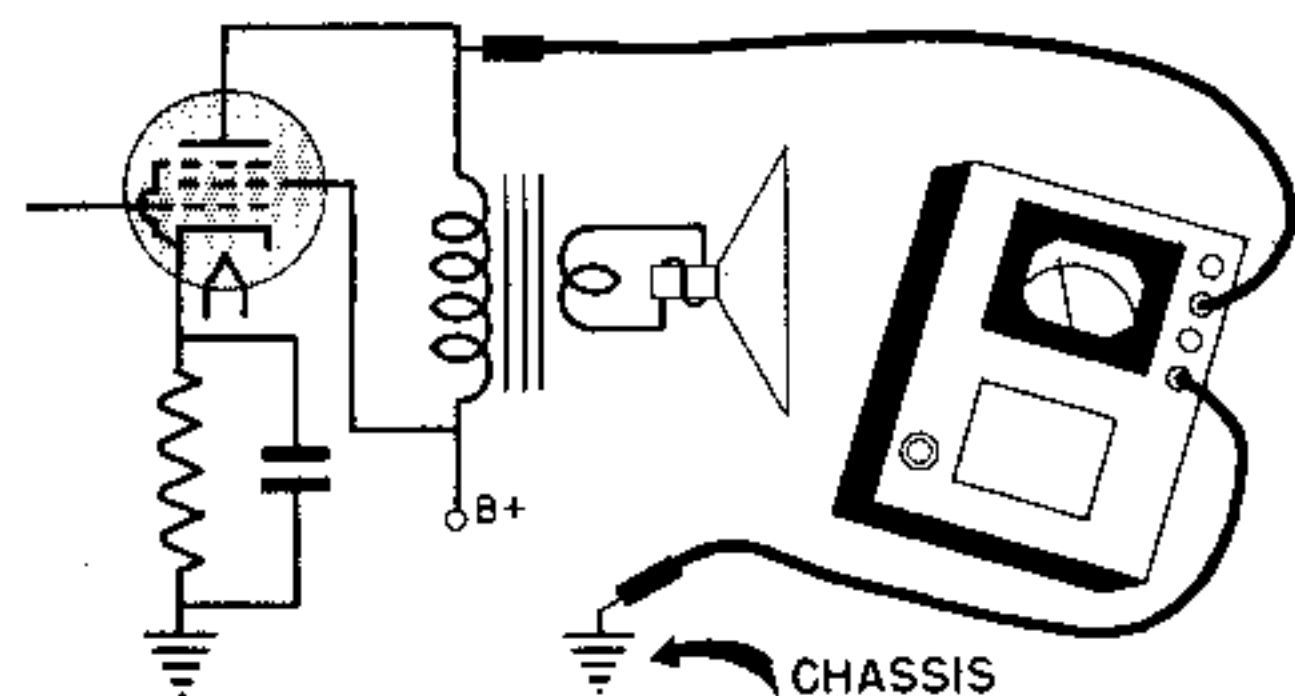

FIGURE 15  
A. C. voltmeter, with built in d.c. blocking condenser, used as output meter.

push-pull stage and ground as shown in Fig. 16. If the multimeter is of the high resistance variety (at least 10,000 ohms per volt), or is a vacuum tube voltmeter, it may be used as a d.c. voltmeter and connected directly across the diode load resistor to read a.v.c. voltage. If the volume control is used as the diode load, then the d.c. voltmeter should be connected across the volume control -

## GENERAL ALIGNMENT PROCEDURE

### TRF Receivers

this is illustrated in Fig. 17. An output indication can also be obtained by connecting an a.c. voltmeter across the receiver's loudspeaker voice coil, as shown in Fig. 18. This method is not

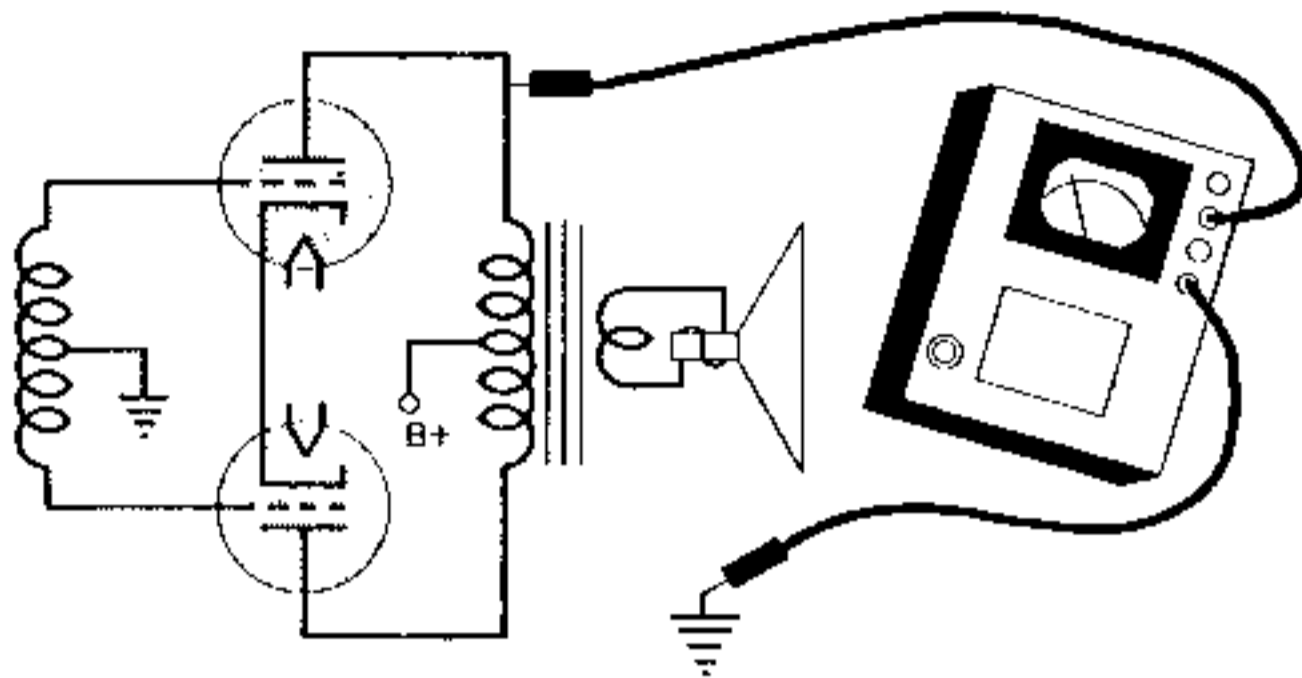

FIGURE 16

An output meter can be used between the plate of one push-pull tube and ground.

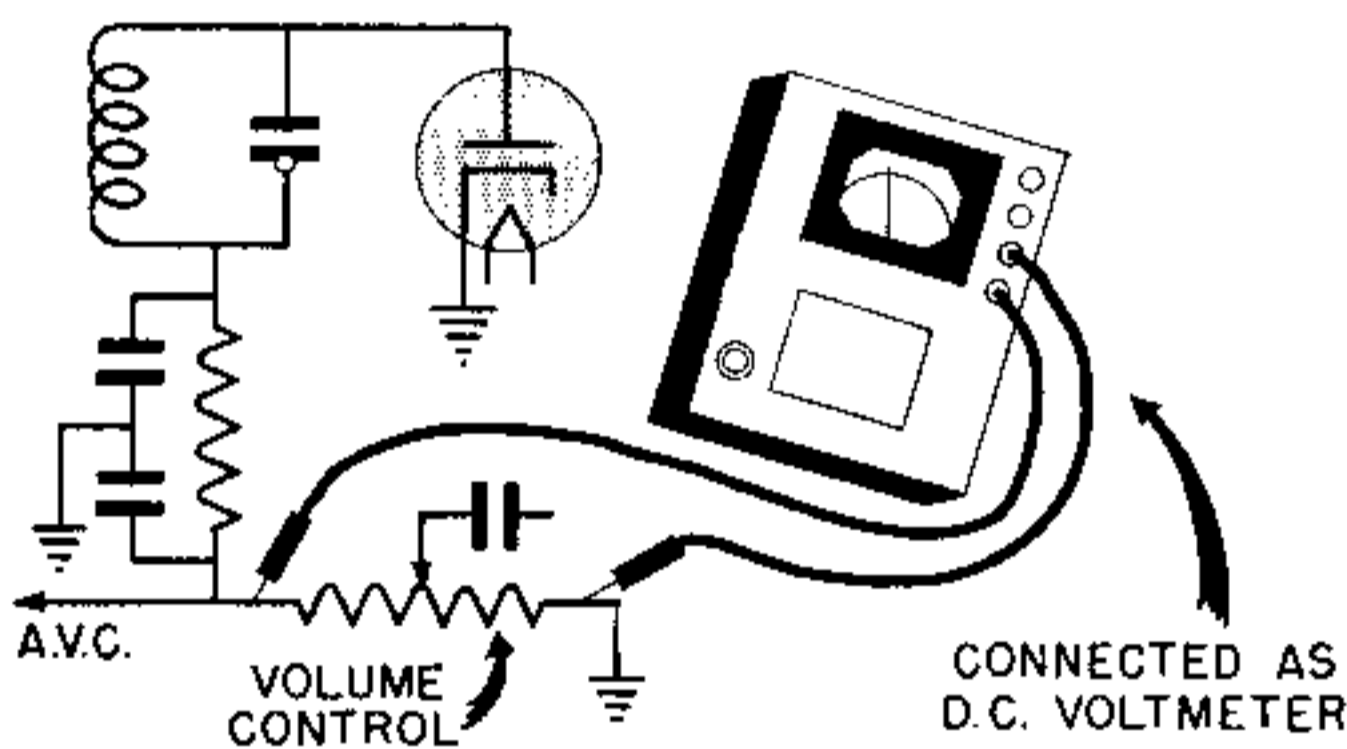

FIGURE 17

A high resistance, or vacuum tube voltmeter, used to measure a.v.c. voltage as an output indication. Most servicemen feel this method gives best results.

as satisfactory as those previously mentioned.

If the receiver has a tuning indicator of the "magic-eye tube" type, a "shadow meter," or similar type of tuning indicator, this may be used to indicate when proper adjustments have been made.

In an FM receiver where a limiter is employed, a microammeter is usually recommended for aligning the i.f. and preselector stages. It is inserted in series with the limiter grid circuit, and preceding stages peaked for maximum limiter current. A vacuum tube voltmeter or high resistance d.c. voltmeter is then used in discriminator alignment.

In recent years, practically the only TRF receivers manufactured have been very inexpensive a.c.-d.c. midget receivers. A typical example is shown in Fig. 19.

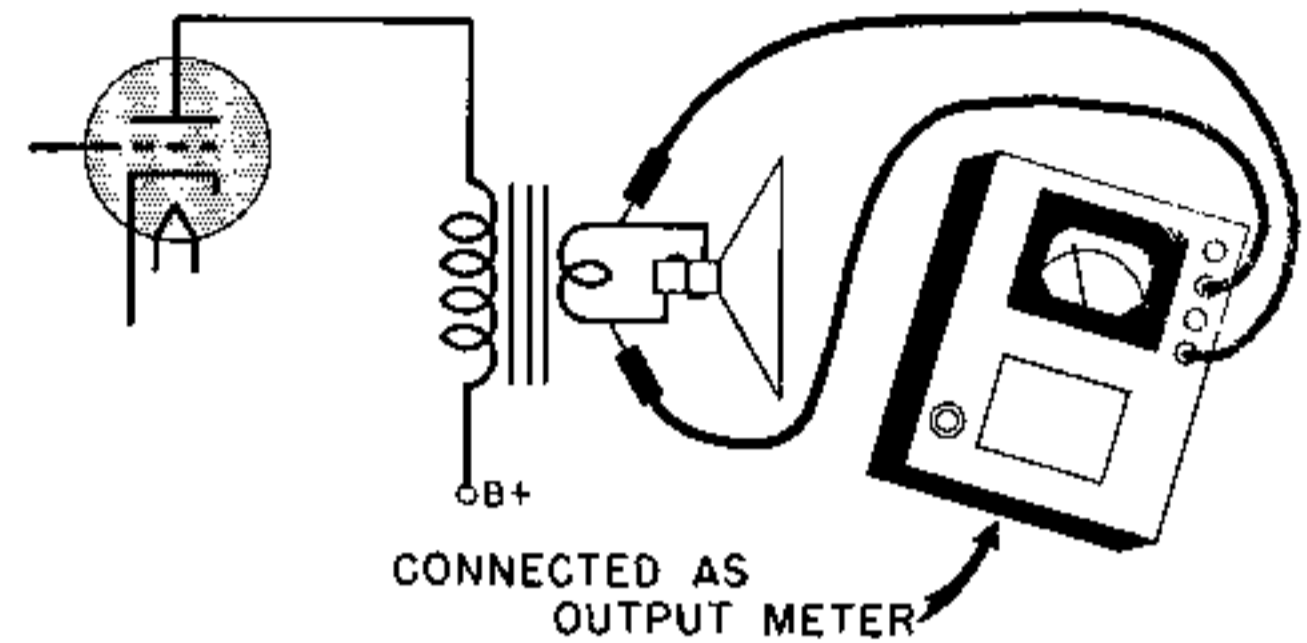

FIGURE 18

Output indication obtained across loudspeaker voice coil, with an a.c. voltmeter. Use this method only when other methods are extremely inconvenient.

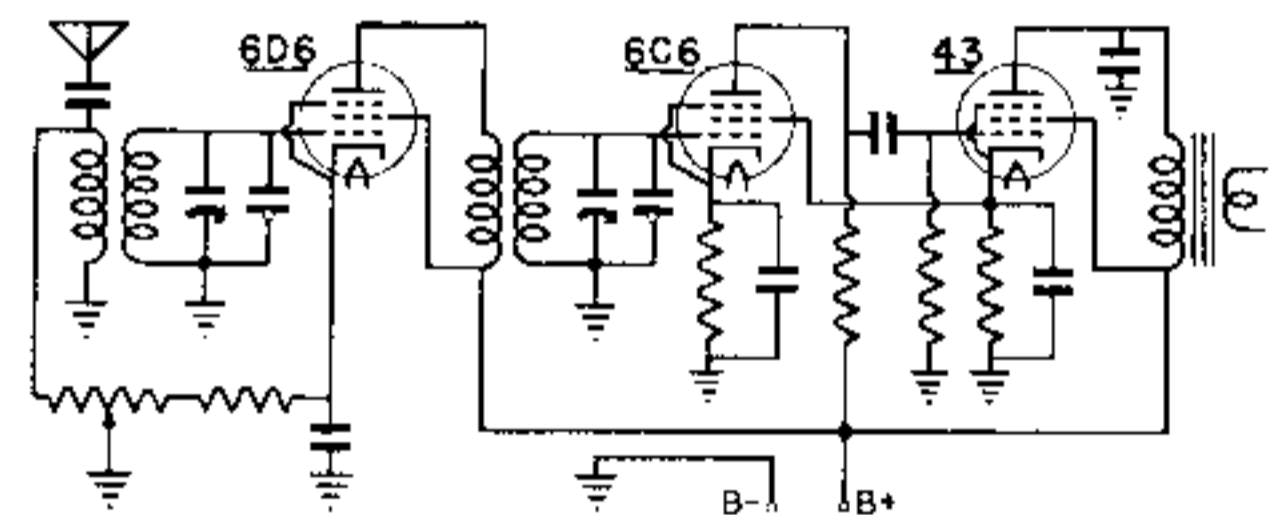

FIGURE 19

A typical midget t.r.f. set of simple design.

These sets are quite simple and have but a single r.f. stage, which feeds into a detector circuit.

However, many of the older TRF receivers are still in existence, and these, too, need alignment. The following instructions will show you how to align TRF sets that use screen grid or pentode tubes in the r.f. stages. Older receivers with triode tubes in r.f. stages may use the neutrodyne circuit, which requires an additional adjustment. This will be described later under the subject "Neutralization."

Almost every TRF radio has a set of r.f. trimmer condensers. One condenser is in parallel with each section of the

main tuning condenser, so that each tuned circuit can be adjusted to give maximum output at the same signal frequency. The adjustment is always made near the high-frequency end of the band, because small circuit changes have the greatest effect at this end. If no over-all equalizing adjustment is provided, the rest of the tuning band may not be in adjustment for maximum response, but will usually be satisfactory.

Since few TRF receivers have diode detectors or a.v.c. circuits, you will probably connect the output meter between the plate of the output tube and ground, or across the loudspeaker voice coil. Next, disconnect the antenna wire, and connect the "hot" lead of the signal generator cable to the antenna terminal of the receiver. Connect the ground lead of the signal generator to the ground post of the receiver (or to the chassis if there is no ground post).

To make the alignment, tune the signal generator to a frequency of approximately 1400 kilocycles. Tune the set's dial to exactly the same frequency. Turn on both the signal generator and the set, and allow them to warm up for a few minutes so that they will become stable in operation. Then adjust each trimmer, in turn, until the output indicator gives maximum reading. (You will normally find that these trimmers are mounted right on the tuning condenser gang.) This usually completes the job.

A few of the very early TRF receivers did not have trimmer condensers. With some of these sets it is possible to make a rough alignment by varying the position of the gang tuning condenser rotor plates on their shaft, or by moving the leads of the tuned circuit closer to or farther from the chassis (thus changing the stray capacities in the circuits). Frankly, such jobs usually take much more time than the final result warrants. The customer should purchase a more modern receiver.

A few of the better early TRF receivers were designed to be selective and sensitive over the entire broadcast band. To make this possible, not only do these sets have trimmers that are used to make the initial adjustments, but also the last plate of each of the rotor sections

of the tuning condenser is split or segmented, so sections of the rotor plate may be bent in or out at various points over the tuning range (see Fig. 20).

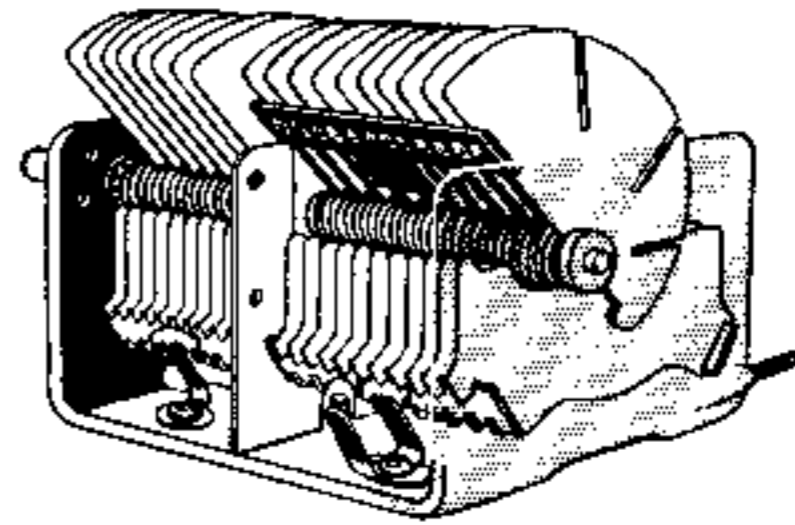

FIGURE 20

This illustrates the split rotor used in the tuning condensers of both old and modern sets. For clarity, the end bracket of the condenser has been shown in phantom.

This makes it possible to align the circuit at several frequencies over the band.

To align this kind of receiver: (1) Adjust the trimmers for maximum output with the signal generator and receiver tuned to 1400 kc. (2) Rotate the tuning condenser gang until only the first rotor segment meshes completely with the stator section. Retune the signal generator to give maximum output at this frequency. (3) Bend the first segment (the meshed segment) on the rotor of each condenser section in or out until the output indicator shows maximum voltage. (4) Turn the tuning knob again until the second rotor segments are completely meshed, retune the signal generator for this new setting, and repeat the adjustments for the second segments on each of the condenser sections. (5) When all the split segments have been adjusted in this manner for maximum output, retune the receiver to 1400 kc., and readjust the trimmers to compensate for any effect caused by bending the rotor plates.

When you are to align a TRF receiver, be sure that you first give it a thorough overhauling. Clean out all dust and grime from the r.f. coils and the tuning condenser, and blow out all dust and dirt from the chassis. Don't align any receiver until all shields and shield connections are in place, and don't adjust any trimmer condenser until you know its purpose. An important rule to remember in aligning TRF's is that the

trimmers you are to adjust will always be connected in parallel with the main tuning condensers and will usually be on the gang condenser itself. Don't touch any trimmer not connected in parallel with the gang tuning condenser; it is in the circuit for some purpose other than alignment.

### Neutralization

At one time the neutrodyne receiver was extremely popular, so you may still occasionally get one to service. It was one of the first TRF receivers to have high sensitivity without being prone to squeal or oscillate. Squeals, or oscillation, was eliminated by feeding back energy out of phase with that which would otherwise cause oscillation. Therefore, whenever such a receiver gets out of balance, or if there is any change in its tubes, it may oscillate.

You can be sure a set is a neutrodyne if it uses triode tubes as r.f. amplifiers (screen-grid tubes made the neutrodyne circuit unnecessary) and has trimmers on the chassis that are not in parallel with the tuning condenser gang. On some receivers you may have to look carefully for a hidden neutralizing condenser. An example is a series of early RCA receivers in which the neutralizing trimmers were actually underneath the tuning condenser gang. It was necessary to take the entire gang off the receiver to reach a neutralizing adjustment.

The alignment procedure for a neutrodyne is the same as for other TRF sets. However, if the receiver is oscillating or squealing, you must neutralize it before alignment. If the set is not oscillating, go ahead with the alignment procedure until the set goes into oscillation, at which point you will have to neutralize. The general neutralizing procedure is as follows:

1. Open the filament or heater circuit of the tube in the last r.f. stage by unsoldering a supply lead from the filament terminal on the tube socket. (An alternate method is to place a small section of an ordinary soda straw over one of the tube's filament pins. Any method which will allow the tube to be placed in its socket without filament

voltage applied is satisfactory.)

2. Turn the receiver on. Be sure the disconnected tube does not light. Tune the receiver to a local broadcast station operating on a frequency somewhere near 1500 kc., or connect your signal generator to the antenna and ground terminals of the receiver and tune both to the same frequency near 1500 kc.

3. With no filament emission, this one tube will have no plate current. However, if the set is out of neutralization, the signal to which the receiver is tuned can be heard from the loudspeaker. This means that the signal is passing from the grid to the plate (via inter-electrode capacity) inside the cold tube. This stage therefore needs neutralizing.

4. Adjust the neutralizing condenser in the stage until the signal is at minimum volume or cannot be heard, then retune the r.f. trimmer for this stage for maximum value, and readjust the neutralizing condenser for minimum volume. This completes the neutralizing adjustment for one stage. (IMPORTANT: Once a stage has been neutralized, do not change the tube in that stage, otherwise you may have to reneutralize.)

5. Turn off the set, and restore filament voltage to the tube.

6. Repeat this procedure for all other r.f. stages, one by one, working toward the antenna.

When you have neutralized all stages, the set should not oscillate at any point over the band. However, if you find that it squeals at some other frequency, say at 800 kc., after you have eliminated the squealing at 1500 kc., you may find it necessary to reduce regeneration in some other way, possibly by reducing the plate voltage.

Sometimes a tube cannot be neutralized properly. If you find a stage does not respond to neutralization, and can trace oscillation to that stage, try another tube in the stage, and check the stage wiring carefully. Before you can neutralize, all shields must be in place. If there is any missing shielding, it must be found or replaced.

### Basic Superheterodyne Alignment

Introduction: In a TRF receiver, most alignment was carried out at only

one frequency. In a superheterodyne, a different case is encountered - a number of different circuits are used and a number of different alignment steps are necessary. The general procedure for aligning a superheterodyne receiver is first to align the i.f. amplifier by feeding in an i.f. signal and adjusting the i.f. trimmers (or coilcores) to give maximum output at this frequency. Then the oscillator and preselector sections are adjusted to give maximum output and to track properly with the dial.

The following general information on alignment is presented to be used in cases where you do not have manufacturer's alignment instructions available. If manufacturer's data on alignment is available, we suggest it be followed.

The Model 88 Signal Generator is designed to have practically no noticeable frequency drift as it warms up. However, the average superheterodyne receiver does drift slightly in frequency during the first five or ten minutes of operation. It is a good plan to allow sufficient time for the receiver to warm up before aligning. The signal generator may also be turned on during this warm up period.

In some sets, movable iron cores (called "tuning slugs") in the inductances may be used for alignment rather than trimmer condensers. Therefore, where we mention trimmer adjustments, if a receiver has "slug" adjustments, then the iron cores are varied - basic technique is still the same.

First, learn the i.f. frequency of the set to be aligned. There are several ways that the i.f. frequency can be determined. One way is to refer to any information that may be on the set chassis, inside the receiver cabinet, on the i.f. transformer shield cans, or mounted somewhere on the cabinet. Occasionally, the small name plate or card on which the model number of the set is printed will also have the i.f. frequency. If such information is not available, refer to the schematic diagram or to servicing data for this set as published by the manufacturer, or refer to any of the standard service manuals for this data.

Finally, if you are unable to obtain the information from any other source,

you can usually experimentally determine the proper i.f. frequency.

Let us outline the method for experimentally determining the i.f. frequency.

1. Connect the signal generator to the input of the set - to the antenna post and ground or to the loop antenna as has been previously outlined.

2. Connect the output indicator in the proper part of the set, using the methods outlined under that section.

3. Now, turn the "FUNCTION" switch to "R.F. MOD."; the "BAND" switch to position "A"; the "FINE ATTENUATOR" control to its maximum position; and the "COARSE ATTENUATOR" control to the "HI" position.

4. Turn the signal generator main tuning knob until the dial pointer is at the extreme right-hand end of the scale - this corresponds to the highest frequency setting of Band "A" - 550 kc.

5. Short out the oscillator section of the receiver's tuning condenser by soldering a small strip of wire between the stator and the connection to the rotor plates, or to ground. Don't solder directly to the stator plates, of course, but to the lug connecting to the plates. (A short jumper lead with small alligator clips at each end can be used for this operation. No soldering is then necessary.)

6. Tune the signal generator gradually towards the lowest frequency (170 kc.) on Band A. As you do this, you should find a signal comes through the receiver which is louder at one point than at any other. If this is near one of the standard i.f. frequencies, use it as the i.f. frequency of the set for alignment. You will find that this should occur at one of the standard frequencies of 175, 262, 455 (or 456), 465, or 470 kilocycles.

The receiver's volume control should be in a maximum position when making this test to determine the i.f. frequency of the set. The tuning dial of the receiver should be set near the low frequency end (condenser plates meshed). Once you have determined the i.f. frequency of the receiver, you can follow the general alignment procedure given on following pages.



## The Basic Superhet Alignment Technique

1. Plug in and turn on both the signal generator and receiver - allow a few minutes for them to warm up.

2. Connect the output indicator as previously described. (With sets having a.v.c., whenever possible use a high resistance d.c. voltmeter to measure a.v.c. voltage as an output indication, as shown in Fig. 17.)

3. Set the tuning dial of the receiver to the low frequency end of the scale.

4. Turn the set's volume control to its maximum volume position.

5. Short out the local oscillator by soldering a short piece of wire between the lug for the stator plates and ground or rotor lug, or use any other convenient method.

6. Connect the signal generator "hot" lead to the antenna post of the receiver and the "ground" lead to the ground post of the set - or, if a loop antenna is used, make the connections as illustrated in Fig. 11 or 12. If the receiver has an r.f. preselector stage, it may be necessary to connect the signal generator between the signal grid of the converter, or mixer tube, and ground to get an i.f. signal through the receiver.

7. Set the signal generator exactly to the i.f. of the receiver - using the "BAND" switch to select the proper band. (Normally i.f.'s are found on Band A.) Set the signal generator attenuator controls until a suitable indication is obtained on output meter.

8. Adjust the i.f. trimmers for maximum reading on the output meter. This would correspond to adjusting trimmers D, E, F and G in Fig. 21.

You will usually find the i.f. trimmers on top, on the side, or at the bottom of the i.f. transformer shield cans, although there are a few early receivers in which the i.f. trimmers are mounted separately from the i.f. transformers. (With the latter, you may have to depend on the manufacturer's instructions or trace the circuit to determine which trimmers adjust the i.f. amplifier and which are used for other purposes.)

In some sets, the output i.f. transformer (the one feeding the second

detector) may have only one trimmer. There are also a few sets in which one trimmer is mounted at the top of the can and the other on the bottom, so be sure to look carefully for two trimmers before deciding there is only one.

9. Repeat all i.f. trimmer adjustments to eliminate the effects of any interaction between trimmers.

If the i.f. transformers are very badly out of alignment (usually due to someone tampering with the trimmer adjustments), it may not be possible to force an i.f. signal through the entire receiver. It will then be necessary to first align the i.f. section, one transformer at a time.

Start by connecting the output of the signal generator between the control grid of the i.f. amplifier tube and ground (points 1 and 2 in Fig. 21). With the signal generator at the specified i.f., adjust the trimmers of the last i.f. transformer for maximum output. (If the i.f. frequency is not known, set the signal generator to one of the standard i.f. frequencies, usually 456 kc., and adjust trimmers, looking for a normal peaking of the output. By experiment and experience, you may be able to find an i.f. which will work satisfactorily.)

When the i.f. amplifiers of the receiver have been properly aligned for maximum output indication, it is necessary to align the "front end" (R.F., Mixer, and Oscillator sections) of the receiver.

10. Remove the shorting connection used to cut out the operation of the local oscillator and tune the receiver to its highest frequency dial setting.

11. Set the signal generator to the same frequency. Then adjust the oscillator trimmer for maximum output. (This trimmer is usually located on the oscillator section of the tuning condenser gang, adjustment B in Fig. 21.) If the receiver is badly out of calibration, it may be necessary to tune the signal generator back and forth near the frequency of the receiver, until a signal goes through the receiver. Then the receiver's oscillator trimmer can be adjusted until the receiver and signal generator are tuned to the same frequency, and maximum output is obtained. At this point, it is also a good plan to make sure that the

receiver's dial pointer has not shifted mechanically, and thrown the receiver calibration off.

12. Tune the receiver and signal generator to a frequency of about 1400 kc., and adjust the preselector trimmer for maximum output (adjustment A in Fig. 21). This trimmer is generally on the preselector section of the gang.

frequency adjustment.

13. Make a low-frequency adjustment by tuning the set and the signal generator to approximately 600 kc. Adjust the low-frequency padder, adjustment C in Fig. 21 (or the oscillator coil core), for maximum output. When the maximum in sensitivity is wanted, it is better to use the following procedure, known as

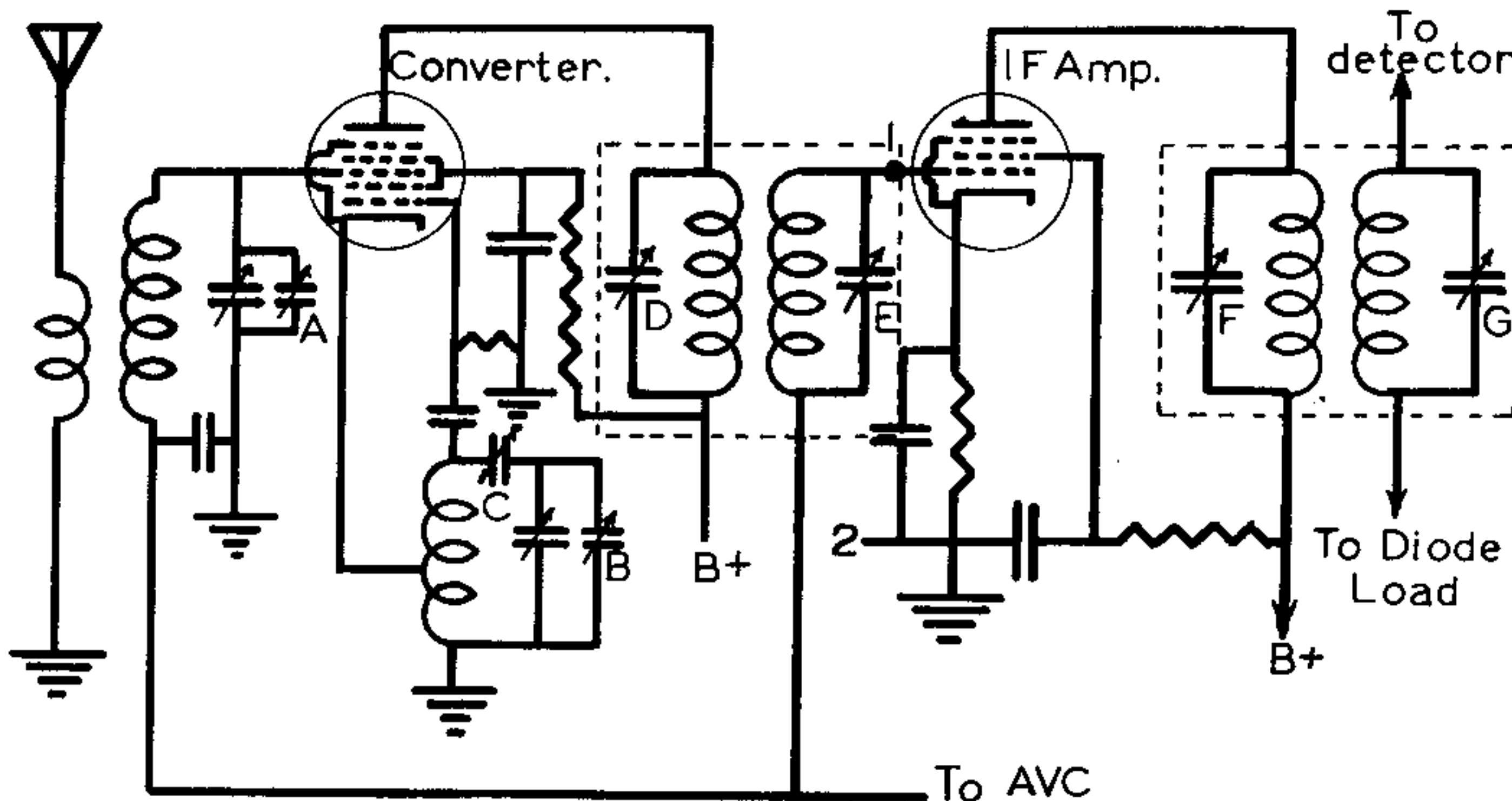

FIGURE 21

Typical superheterodyne converter and i.f. stages.

ADJUSTMENTS: A - Preselector Trimmer, B - Oscillator Trimmer, C - Oscillator "Padder", D-E - Input I.F. Trimmers, F-G - Output I.F. Trimmers.

Some receiver alignment instructions will tell you to adjust the oscillator and preselector stages together at 1400 kc. This may prove satisfactory. However, it is often possible to increase the sensitivity of the receiver between 1400 kc. and 1600 kc. by peaking the oscillator trimmer at approximately 1600 kc.

If the oscillator circuit uses specially cut tuning condenser plates (normally smaller in size than the r.f. section of the variable condenser), there will probably be no low-frequency adjustment. You will be through with the alignment after carrying out the above procedure. However, if there is a padder condenser (or if the oscillator coil core is adjustable), you should make a low

"rocking."

To make a rocking adjustment, tune the signal generator to 600 kc. and leave it set at this frequency. Now tune the receiver to get maximum output, regardless of the dial setting. Note the exact output meter reading. Then, change the setting of the oscillator padder condenser (or of the coil core) slightly, and re-tune the receiver for maximum output. Notice whether the reading on the output meter has increased or decreased. If the reading increased, keep on changing the oscillator adjustment in the same direction, tuning the set each time, until you find the point at which you get the maximum output meter indication. If the second reading is less than the first,

change the oscillator adjustment in the opposite direction, and retune the set, keeping up the procedure until the highest output reading is obtained.

This rocking procedure increases the receiver sensitivity (at the sacrifice of exact receiver dial calibration), by effectively tuning the local oscillator and preselector simultaneously. (Changing the receiver dial setting tunes the preselector, while the oscillator is tuned by the combination of padder adjustment and the dial change.)

14. Go back to the high frequency setting of 1400 or 1600 kc. and readjust the oscillator trimmer for maximum output at this frequency (if you made any change in the padder or oscillator coil core setting). Then repeat the low-frequency adjustment. After one or two repetitions of these adjustments, the receiver should track reasonably well over the broadcast band, and the set should have maximum selectivity and sensitivity.

Notice that this alignment procedure is not a matter of making one definite adjustment, but is rather a back-and-forth process. One adjustment affects the other, so you have to make slight changes in both to get the best possible setting of the trimmers.

#### Additional Information

Where the receiver uses i.f. transformers of the "band-pass" or "high fidelity" type, slightly different alignment techniques will be used. Also, where "amplified" a.v.c. or a.f.c. circuits are used, a slightly different procedure is necessary. For these special applications, and for regenerative detector sets, using regeneration in the second detector, refer to your regular NRI lessons or to specific instructions given by the manufacturer of the set.

Some receivers may have a wave trap, tuned to the i.f. frequency, either in the antenna circuit as illustrated in Fig. 22, or between the first r.f. amplifier and the converter stage. In this case, after other alignment procedures have been carried out, the signal generator is set to the i.f. frequency of the receiver (or to the frequency of the wave trap if different from the i.f. of

the set); the output of the signal generator connected to the antenna and ground of the receiver; and the adjustment carried out for minimum indication on the output indicator.

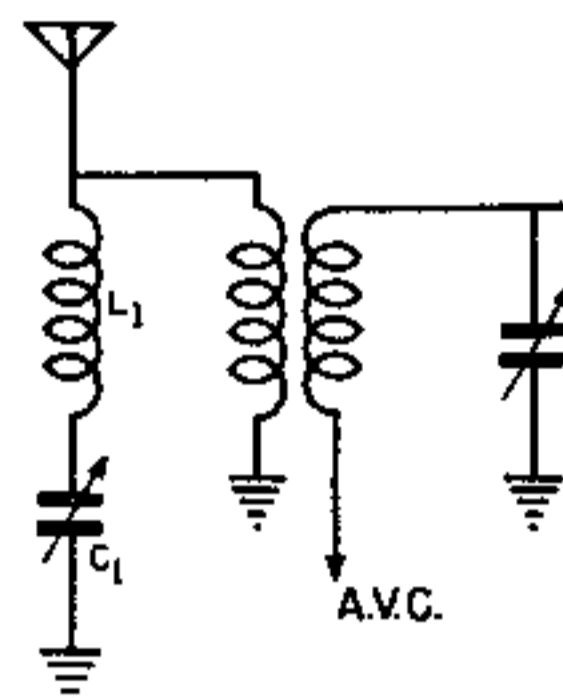

FIGURE 22  
Showing "Wave Trap"  
in the antenna circuit.

In most cases, you will find that no wave trap is being used, and this adjustment can be disregarded.

#### Multi-band Receivers

Where a multi-band superheterodyne is to be aligned, the i.f. amplifier is first aligned, using a conventional technique as outlined. You can then turn to the preselector and oscillator stages. The all-wave receiver has, of course, a number of preselector and oscillator circuits - one of each for each wave band. There are two major systems used for all-wave reception. In one, each circuit has its own set of coils, trimmers, and padders. In a set of this sort, the bands can be aligned in any order - using the previous outlined technique of adjusting at the high-frequency and low-frequency end of each band. In these cases you would use signal generator readings corresponding to dial readings on the receiver. You can adjust the broadcast band first if you want to, then skip from short-wave band to short-wave band. This circuit is illustrated in Fig. 23.

The other system uses a single set of coils for all bands. The coils are provided with taps, and as much of each coil is used for each band as is needed to give the required inductance. For example, the highest frequency band uses

a single section of the coils. Since a circuit tuned to a lower frequency requires more inductance, the next highest frequency band uses two sections of the coils, and so on. A set with this arrangement, known as the series coil connection, must be adjusted from the highest

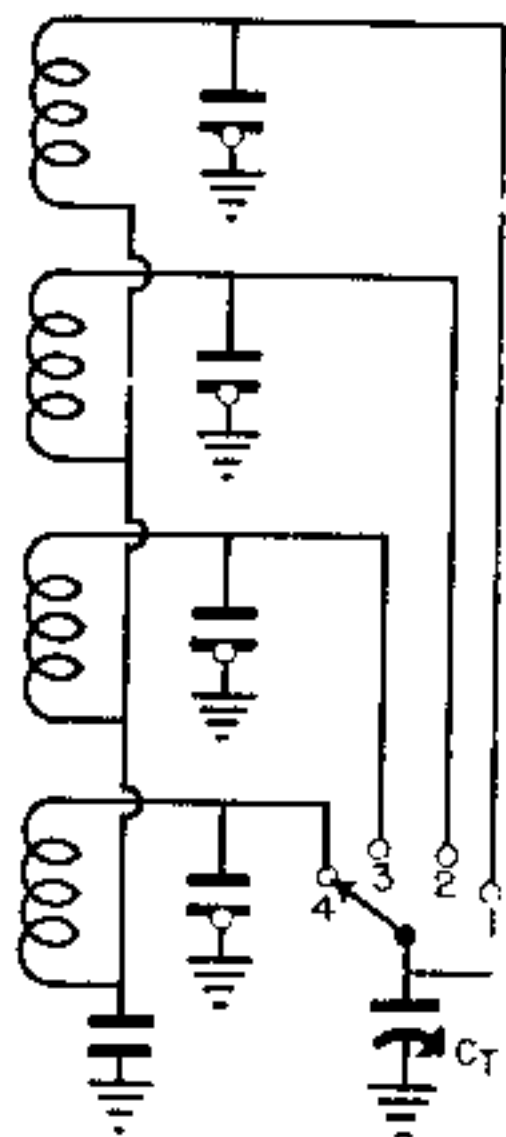

**FIGURE 23**  
This is the preselector circuit of an all-wave receiver using independent tuned circuits for each band. As you can see, the coil and trimmer of each circuit are separate from those in all the other circuits. You can align the bands of such a receiver in any order you wish.

frequency band downward. The setting of the trimmers in each circuit affects the capacities in the other circuits, and it is impossible to compensate for this unless the highest frequency band is aligned first. Refer to Fig. 24 for an example of this type of circuit. Proceeding this way, band by band, you will align the broadcast band last.

If you have the manufacturer's instructions, they will list the adjustments in the order in which they should be performed, if the order is important. However, when you do not have the manufacturer's instructions, you must either examine the set carefully, determine which type it is, or follow the general rule of aligning the highest frequency band first in all cases, working downward through the low-frequency bands.

You may encounter some difficulty in aligning a short-wave band if you make an improper adjustment of the oscillator high-frequency trimmer. As you know, a superheterodyne should normally be aligned so that the local oscillator frequency is above the preselector or signal frequency by the amount of the i.f. If any band is

aligned so that the oscillator frequency is below the preselector frequency by the amount of the i.f., the set will still play at the high-frequency end of the band, but it will be impossible to make it track properly at the low-frequency end. To avoid this difficulty, do not turn the oscillator trimmer very far when you are making a high-frequency adjustment in a short-wave band that is reasonably well aligned. If the set has been tampered with, or if you accidentally turn the oscillator trimmer far away from the original setting, make sure that the oscillator frequency is above the preselector frequency. To do so, adjust the set and your signal generator to a frequency near the high end of the band and run the oscillator trimmer adjusting screw out slowly, being careful not to bring it out so far that the condenser comes apart. If the trimmer has a wide tuning range, you should pick up the signal at two different screw positions as you back the screw out. If you do, leave the screw at the outer position (the position that gives the trimmer less capacity). This will make certain that the

**FIGURE 24**  
This is a typical use of a series coil connection in a preselector circuit. The shorting switch is part of the wave-band switch. When this switch is turned to position 1, it touches the contact of position 2 also; coils  $L_2$  and  $L_3$  are then shorted, leaving only  $L_1$  to be tuned by condenser  $C_1$ . When the switch is turned to position 2, coil  $L_3$  is shorted; coils  $L_1$  and  $L_2$  are then in series and tuned by  $C_1$ . When the switch is in position 3, all three coils are in series and tuned by  $C_1$ . To align this set, you must turn the switch first to position 1 and adjust Trimmer  $C_1$ , then to position 2 and adjust  $C_2$ , and finally to position 3 and adjust  $C_3$ .

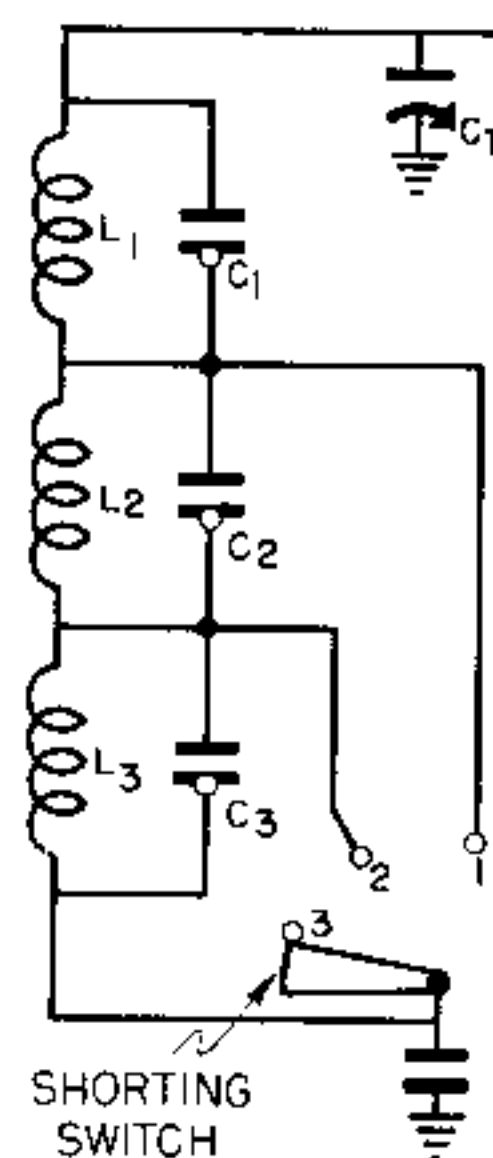

oscillator is above the preselector end frequency.

Remember, in all these alignment techniques, to keep the signal generator output at an average or low value, unless the set is so insensitive that considerable signal strength is needed. The

purpose of this is to as nearly as possible approximate the actual operating conditions encountered.

IT SHOULD BE MENTIONED FOR THE BENEFIT OF BEGINNERS, THAT IT IS IMPORTANT TO DETERMINE AN ACTUAL NEED FOR ALIGNMENT, BEFORE ATTEMPTING THE PROCEDURE. DO NOT LOOK TO ALIGNMENT OF RECEIVERS AS A "CURE ALL." OFTEN A WEAK TUBE, OR OTHER SIMPLE TROUBLE, WILL CAUSE A SET TO HAVE WEAK RECEPTION. BY ATTEMPTING TO REALIGN AN IMPROPERLY OPERATING RECEIVER, YOU MAY BE ACTUALLY MAKING AN EASY REPAIR JOB MORE DIFFICULT.

#### Hints on Identifying Trimmers

When aligning all-wave superhet receivers, it is sometimes difficult to identify the various trimmer adjustments on each band. I.F. trimmers can almost always be identified, since they are either in the "i.f. cans" or else connected to the i.f. coils.

Where the oscillator and preselector trimmers are hard to identify, proceed as follows:

1. Turn both set and signal generator on and connect the signal generator to the antenna and ground posts of the receiver as outlined under the general alignment procedure.

2. Turn the band-switch of the receiver to the highest frequency band and tune the set to the high-frequency end of the dial. Volume control in maximum position.

3. Adjust the signal generator to the same frequency as the receiver - use a modulated r.f. signal and adjust the attenuator controls until a signal can be heard in the loudspeaker.

4. Use an insulated alignment tool and carefully compress the various trimmers in the r.f. and oscillator stages. Don't change the adjustments permanently; simply make a temporary capacity change.

5. When you find that the output from speaker becomes weaker as you compress a certain trimmer - but that the dial setting is not changed, that is the preselector trimmer for that band.

6. When you find that compressing a certain trimmer makes it necessary to retune the receiver dial for peak output -

that is the oscillator trimmer for the band.

7. Repeat this procedure on each band - but don't touch trimmers which you have already identified. Once all trimmers are identified, use the alignment techniques previously outlined.

#### Alignment of FM Sets

FM sets, in general, use one of two basic types of detector circuits. One type is the conventional discriminator detector, with limiter stages employed ahead of the discriminator to eliminate amplitude changes in the signal. The other type employs a "ratio detector" and no limiters are necessary. Slightly different alignment procedures are used.

Let us first discuss the type of FM receiver using a limiter and a discriminator.

It is standard practice to align the i.f. amplifier of an FM receiver before aligning the preselector and oscillator, just as in AM receivers. However, the i.f. alignment is somewhat unique in that the i.f. section up to the input of the limiter tube is aligned first, then the output of the limiter and the input of the discriminator are aligned as a separate step.

The limiter grid current is used as an output indication when aligning the i.f., r.f. and osc. sections, for two reasons. First, the limiter grid current varies directly with the signal strength, so it gives an accurate output indication. Secondly, in normal operation, the limiter should draw a grid current of 50 microamperes or more when stations are tuned in to properly load the preceding resonant circuit. We must measure the limiter grid current during alignment to be sure it is the normal amount. This will insure proper loading and hence correct alignment of its input circuit.

A typical limiter and discriminator stage in an FM receiver is shown in Fig. 25. The output indicator should be a microammeter having a range of about 120 microamperes. It is inserted in the grid return circuit at the point marked "X" and it should be by-passed by a .05 mfd. condenser.

A vacuum tube voltmeter can also be

used by reading the voltage dropped across resistor R caused by the grid current. With a normal signal, minimum voltage across R should be at least .0005 times

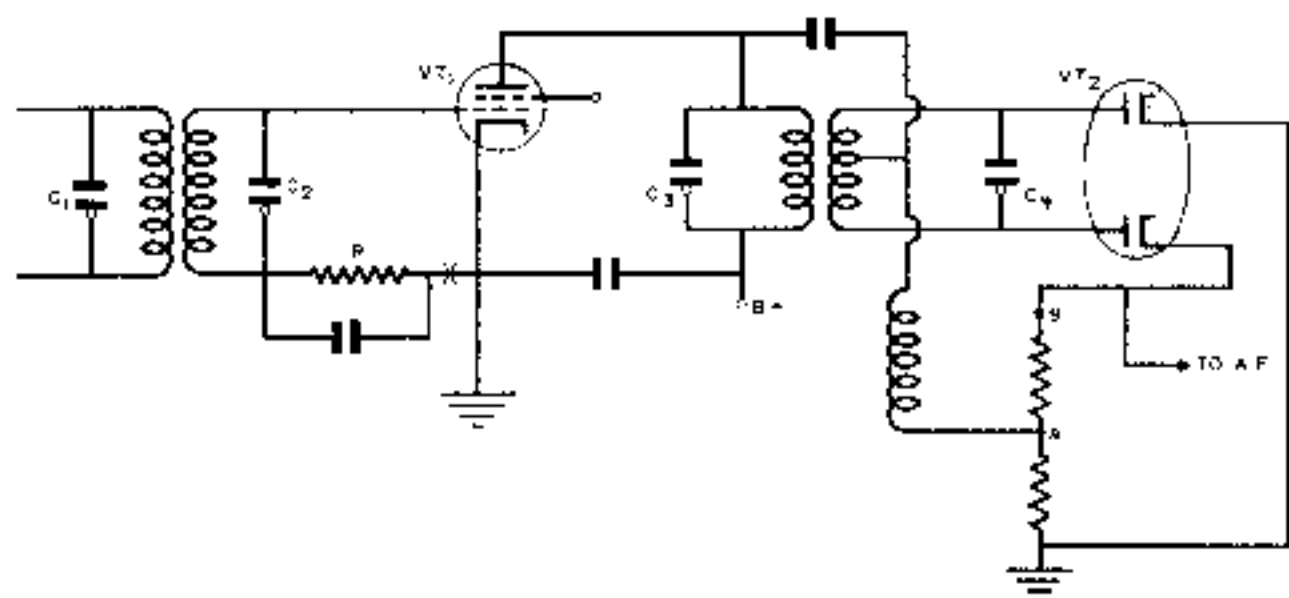

FIGURE 25

Typical limiter and discriminator stages in an FM receiver.

the resistance of R. ( $E = I \times R$ ) for example, if R were 10,000 ohms, and I were 50 microamperes, then .0005 x 10,000, or 5 volts, would be a minimum value. The positive meter lead is connected to the chassis and the negative lead to the ungrounded end of resistor R. For alignment, the signal generator is connected between the control grid of the first detector tube and chassis. The "hot" lead from the signal generator cable will connect to the grid of the tube. Set the receiver dial at the lowest frequency. The local oscillator does not need to be disabled.

The signal generator is tuned to the i.f. resting frequency of the set; this is generally 10.7 megacycles. Use an unmodulated r.f. signal. Adjust the i.f. trimmers for maximum output meter reading. Reduce the signal generator output if the grid current exceeds the range of your output indicator. When you align the limiter input circuit be sure that at least 50 microamperes are flowing before making final adjustment of trimmers corresponding to C<sub>1</sub> and C<sub>2</sub> of Fig. 25.

If the i.f. amplifiers are badly out of alignment, so that little or no output indication can be obtained, start with the signal generator hot probe connected to the control grid of the last i.f. tube (the one just ahead of the limiter), and then work back a stage at a time, aligning each stage as you go.

Finally, you can make an over-all i.f. alignment from the first detector

grid to the input of the limiter. Align each trimmer for maximum current reading on the microammeter or a maximum voltage reading on the vacuum tube voltmeter.

When the i.f. amplifier has been correctly aligned, the output indicator is moved from the limiter stage. If a microammeter was used in the grid circuit, close this circuit when the meter is removed.

You are now ready to adjust the output circuit of the limiter and the input circuit of the discriminator. Leave the signal generator connections and its frequency setting just as they were for the limiter and the i.f. adjustments. You will need either a vacuum tube voltmeter or a high resistance multimeter as an output meter. (1) Connect your meter between point A and ground in Fig. 25, with the negative probe at point A. (2) Then adjust condenser C<sub>3</sub> for a maximum meter reading. (3) Remove the meter probe from point A and connect it to point B, so the meter is between B and ground. (If the meter should read off-scale to the left, reverse the meter polarity.) Now, adjust condenser C<sub>4</sub> for minimum reading on the output meter. Theoretically, the voltage between B and ground should decrease to zero. If it does not, the adjustment for minimum reading is acceptable.

It is advisable to reverse the meter connections as a final check, because the voltage may have passed through zero and actually reversed polarity. Since many vacuum tube voltmeters will not read reverse polarities, you may have passed the zero point without knowing it. A minimum voltage between point B, and ground regardless of meter polarity, completes the i.f., limiter and discriminator adjustments, and none of these trimmers should be touched again.

The preselector and oscillator adjustments are made in the same manner as those for the high-frequency bands on an all-wave receiver. The output meter is connected again as for limiter and i.f. adjustments. R.F. and Oscillator trimmers should be set for maximum readings. It is standard practice to use the unmodulated output of the signal generator when making these adjustments. Manufacturer's information will usually specify

frequencies for adjustment of various trimmers and padders. In general, trimmers will be adjusted near the high end of the band, and padders near the low end.

Since your signal generator covers up to 60 megacycles on fundamentals, and the FM band is 88 to 108 megacycles, it is necessary for you to use second harmonics of the "F" band when aligning the preselector and oscillator circuits of an FM receiver. You can do this quite easily by simply turning the "BAND" switch to position "F" and reading the "F<sub>1</sub>" scale.

### Ratio Detectors

Where a ratio type detector is used, the circuit will probably be somewhat similar to that shown in Fig. 26. In

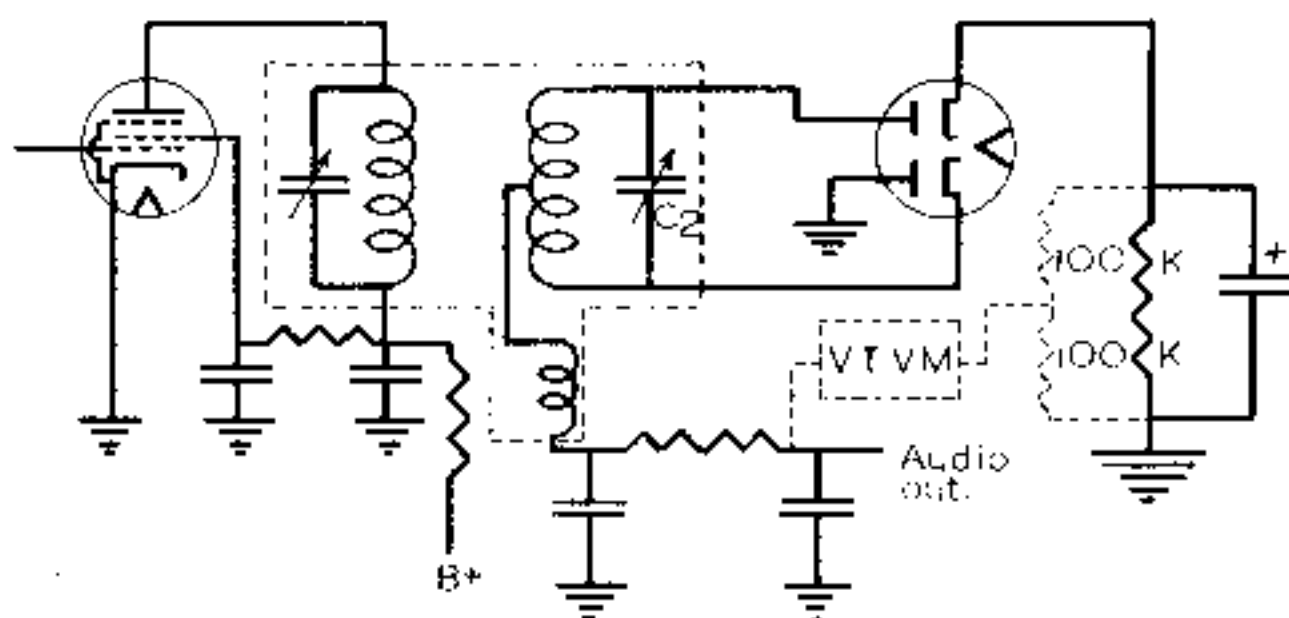

FIGURE 26

Typical FM ratio detector circuit.

this case, the alignment procedure will be as follows:

Two 100,000 ohm resistors are connected as shown by dotted lines. A vacuum tube voltmeter or high resistance voltmeter (not shown here) is connected across these two resistors. The receiver dial pointer is set to the low-frequency end of the dial (88 megacycles) and the signal generator set to the i.f. of the receiver.

All trimmer condensers or "tuning slugs" of the i.f. transformers are then adjusted for maximum output, except the output trimmer in the ratio detector transformer, C<sub>2</sub> in Fig. 26.

Repeat this step in case there is interaction between trimmers.

Next, connect the high resistance voltmeter or vacuum tube voltmeter from the juncture of the two 100,000 ohm resistors to the audio output of the ratio

detector - these connections are indicated by dotted lines on the schematic. Adjust the output trimmer condenser (or iron core slug) on the ratio detector transformer secondary for a zero meter reading. (This is C<sub>2</sub> in Fig. 26.) The meter should register reverse polarity when the slug is rotated through a zero output.

Once zero or minimum meter reading has been obtained, the i.f. stages and the ratio detector are properly aligned. You can then align the oscillator and preselector stages using the conventional techniques previously outlined.

For an output indication when aligning oscillator and preselector stages, the vacuum tube voltmeter or high resistance voltmeter is connected across the two 100,000 ohm resistors which have been temporarily installed. Preselector and oscillator adjustments are made for maximum meter reading.

### Alignment Charts

Many manufacturers furnish, in conjunction with their schematic diagram and servicing data, a trimmer condenser location chart and an alignment chart which gives step by step instructions for aligning the receiver. Most alignment charts are self-explanatory but we feel that an example or two should be given so that you might be familiar with them and their use.

A typical 6 tube superheterodyne receiver, the Zenith Model 6S511 (6S527 - 6S528) is shown schematically in Fig. 27. The trimmer location chart that is furnished in the service data for this set is shown in Fig. 28. The alignment procedure chart, referring to the trimmer condenser location chart, is given in Fig. 29. Note that a step by step alignment procedure is given and instructions are given as to the proper connections for the test oscillator (another term for signal generator), for the type of dummy antenna, and for the setting of the signal generator (this is referred to as the "Input Sig. Freq."). The receiver band switch setting is given along with the dial setting. "B.C." refers to broadcast band and "S.W." to the short-wave band of the set. The proper

trimmer condensers to adjust and their purposes are indicated.

In most cases, the adjustment should be for maximum output on the output meter.

Corporation, is shown in Fig. 30. The trimmer condenser and "tuning slug" locations are given on the chart directly below the schematic.

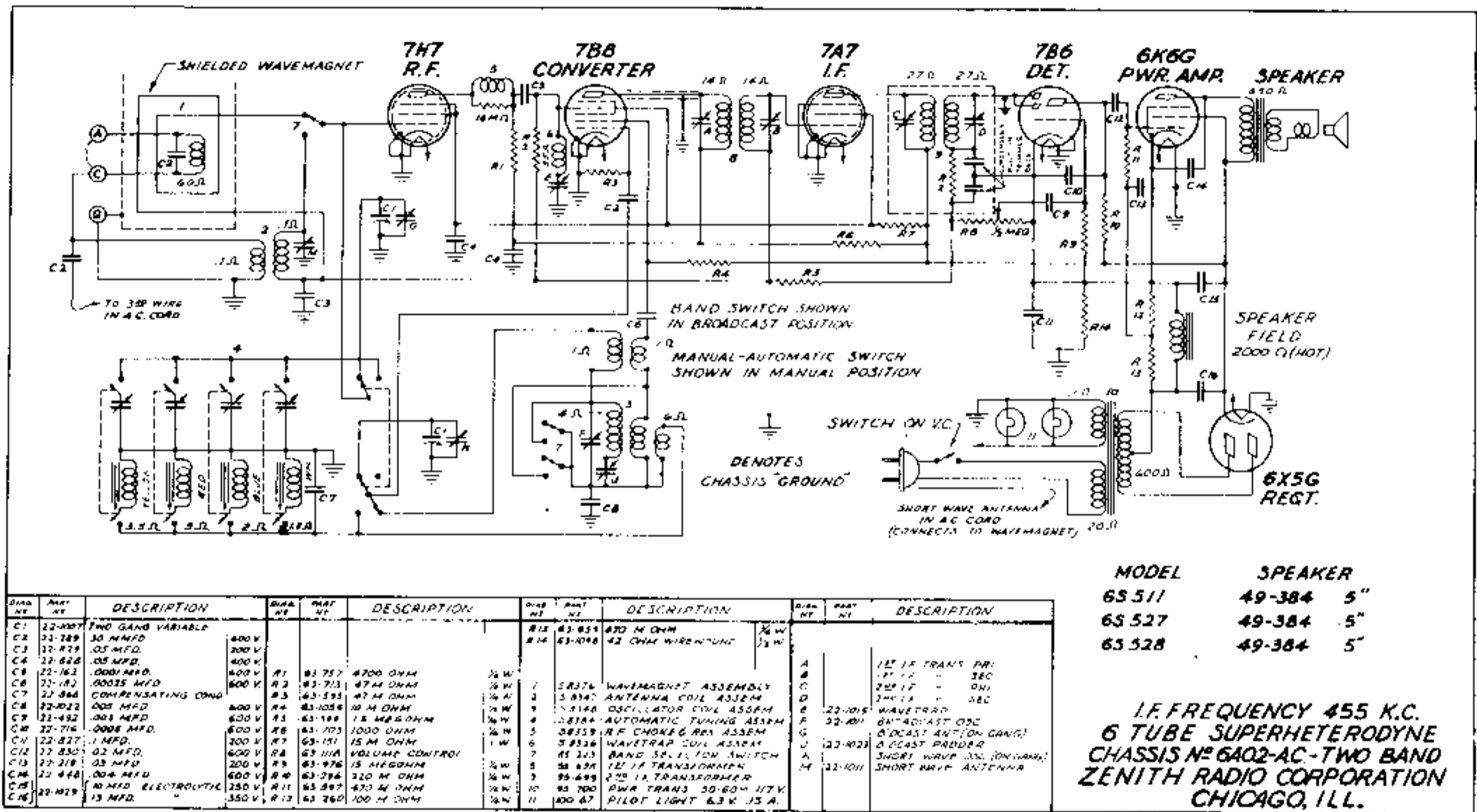

FIGURE 27

Zenith Models 6S511, 6S527, and 6S528.

Occasionally the adjustment is for minimum output (there is such a wave-trap adjustment in the second operation on the chart in Fig. 29.) The alignment procedure is carried on operation by operation, exactly as listed in the chart.

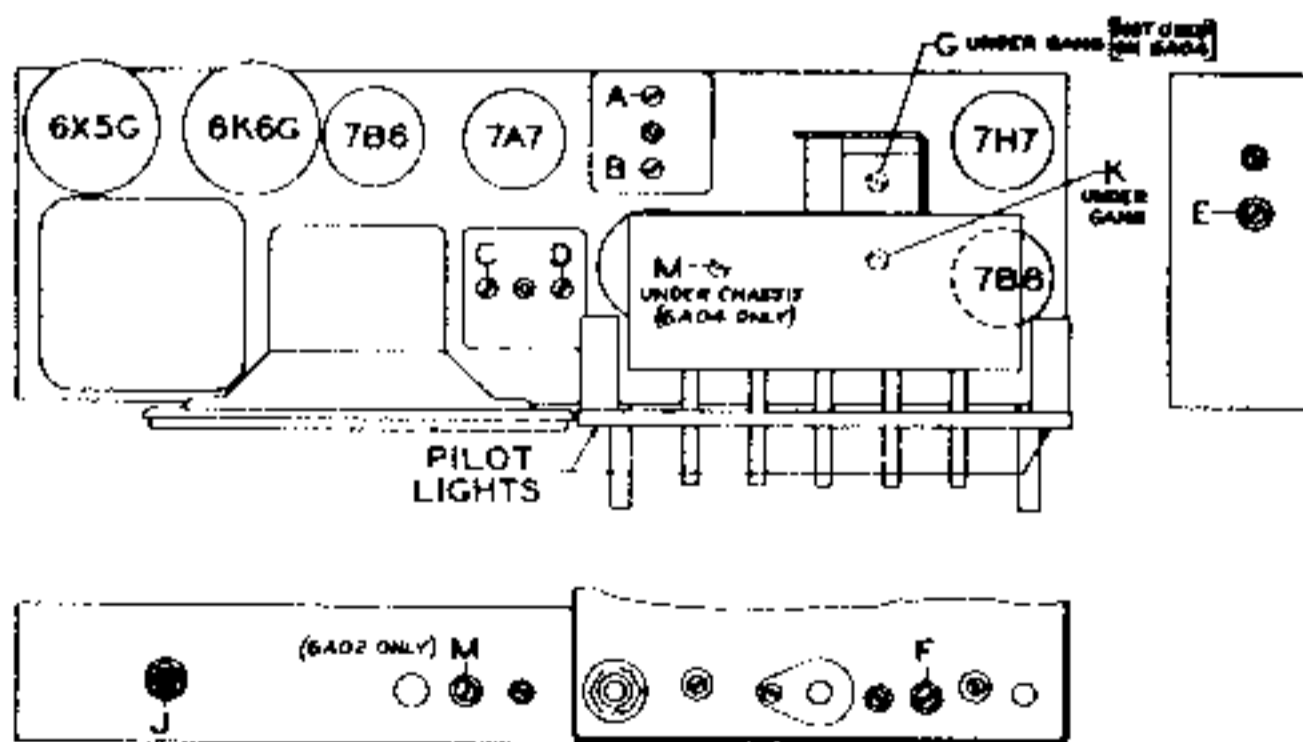

FIGURE 28

Trimmer Location Chart.

The schematic diagram for the FM Pilotuner, manufactured by the Pilot Radio

The proper alignment procedure to use in this typical FM circuit is given in Fig. 31. Although this is only an FM tuner, without audio stages, the alignment procedure is similar to that for a complete FM set, using a ratio detector.

Note that this alignment chart also indicated the type of output indicator to use; the proper meter connections; and the adjustments to be made. It also shows whether the adjustments should be made for maximum or minimum output.

Where complete manufacturer's instructions are available, such as these typical examples, the instructions should be carefully followed. Where such instructions are not available, the general techniques that have been outlined here and in your regular NRI Course should be used.

In many cases, a manufacturer may specify that a vacuum tube voltmeter should be used for alignment. In most



of these cases, a high resistance volt-meter may also be used. Experienced servicemen will often, even where detailed alignment procedures are given,

follow a general technique of their own - the general technique being approximately the same as the procedure given by the manufacturer, but with slight refinements.

Operation	Conn. Test Osc. to	Dummy Ant.	Input Sig. Freq.	Band	Set Dial At	Trimmers	Purpose
1	Converter Grid	.5 Mfd.	455 Kc.	B.C.	600 Kc.	A B C D	Align I.F.
2	" "	.5 Mfd.	455 Kc.	B.C.	600 Kc.	E	Adj. for Minimum
3	Ant.-Gnd.	400 Ohm	18 Mc.	S.W.	18 Mc.	K	Set Osc. To Scale
4	Ant.-Gnd. with 10 Ohm Shunt	.5 Mfd.	1500 Kc.	B.C.	1500 Kc.	F	" "
5	" "	" "	" "	" "	" "	G	Align Ant.
6	" "	" "	600 Kc.	" "	600 Kc.	I	Rock gang & Adj. to Max.
7	" "	400 Ohm	16 Mc.	S.W.	16 Mc.	M	Align Ant.

Ze 6A02

Courtesy of Zenith Radio Corporation

FIGURE 29  
Alignment Procedure Chart.

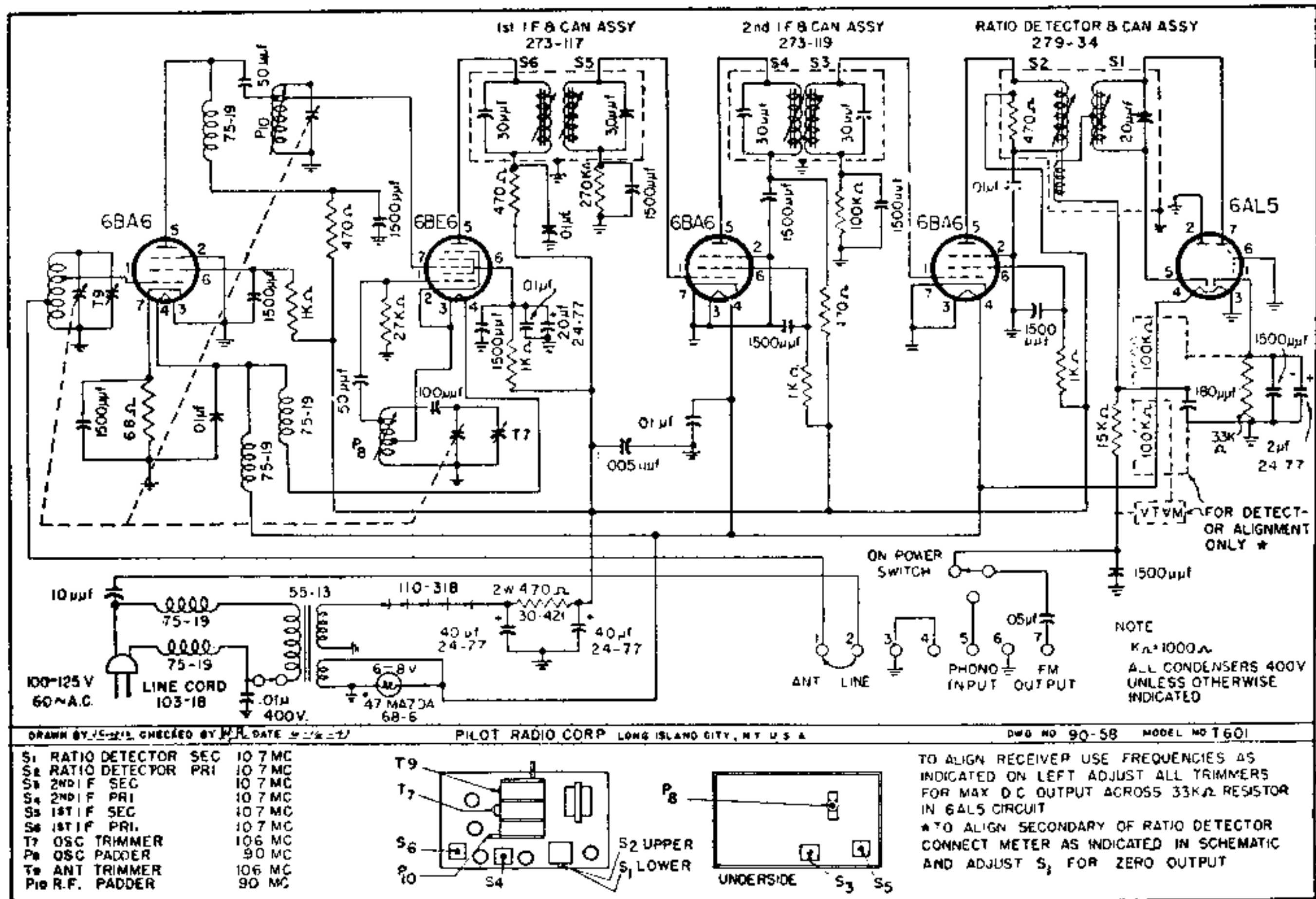

FIGURE 30  
Schematic Diagram of FM Pilotuner.

For example, servicemen do not usually use a dummy antenna. Further, where the manufacturer's instructions may specify the use of one type of output meter (a.c. voltmeter with condenser in series), the serviceman may prefer to measure a.v.c. voltage with a d.c. voltmeter.

defective stage consists of injecting or inserting a signal at a given point in the receiver from a known source. This method can be used to track down trouble throughout the receiver.

Checking a "dead receiver": For example, if the set is dead, set up the signal generator so that an audio signal

CIRCUIT ALIGNED	STEP	RCVR. DIAL POINTER	SIGNAL GEN. CONNECTIONS		METER	METER CONNECTIONS	TRIMMER OR SLUG ADJUSTMENT	PROCEDURE
			FREQ.					
IF	1	88 mc	10.7 mc	Through .01 mfd. cap. to grid of 6BE6	VTVM or high resistance voltmeter	Across two 100K resistors — indicated by dotted lines in schematic	S2, S1, S4, S3, S6, S5	Adjust for maximum output
	2		Repeat Step No. 1					
Ratio Detector	3	88 mc	10.7 mc	Same as No. 1	VTVM or high resistance voltmeter	From: Junction of two 100K resistors TO: Audio output of ratio detector. Connections indicated by dotted lines in schematic.	S1	Adjust meter to zero (Check proper zero set) Meter should register reverse polarity when slug is rotated through zero output.
Oscillator	4	90 mc	90 mc	Through carbon 300 ohm resistor to Ant. Terminal	VTVM or high resistance voltmeter	Same as Step No. 1	P8	Same as Step No. 1
	5	106 mc	106 mc	Same as No. 4	VTVM or high resistance voltmeter	Same as No. 1	T7	Same as No. 1
	6		Repeat Steps No. 4 & 5					
RF	7	90 mc	90 mc	Same as No. 4	VTVM or high resistance voltmeter	Same as No. 1	P10	Same as No. 1
	8	106 mc	106 mc	Same as No. 4	VTVM or high resistance voltmeter	Same as No. 1	T9	Same as No. 1

FIGURE 31

FM Pilotuner Alignment Chart (Follow sequence as indicated.)

You will find, as you gain experience working on different types of sets, exactly what type of servicing procedure you like to follow, and will rely upon manufacturer's instructions only for unusual sets or for some types of multi-band receivers.

#### Use of The Signal Generator in Servicing

Perhaps the greatest use of the signal generator (outside of alignment) is when the "signal injection" method of trouble shooting is used. The signal injection system of isolating the

is produced. This audio signal is fed to the grid of the output tube. If a pentode or beam power output tube is used (as in most modern receivers), you should be able to hear a signal from the loudspeaker with the signal generator set for maximum audio output. If you can hear a signal, this probably means that the output stage, output transformer, receiver loudspeaker and receiver power supply are functioning normally. If so, transfer the "hot" lead of the signal generator to the grid of the first audio amplifier tube and check for an audio signal in the receiver's loudspeaker.

However, if there is no audio signal from the receiver's loudspeaker with the signal generator connected between control grid and ground of the output tube, it indicates trouble either in the output stage, the output transformer, the loudspeaker, or in the set's power supply. A check can be made on the set's power supply quite easily by checking for operating voltages. The loudspeaker can be checked by substituting another speaker or making ohmmeter tests.

Assuming the receiver is working normally from the output stage through to the loudspeaker, the audio signal should be injected at the grid of the 1st. A.F. amplifier. Set the receiver's volume control in the maximum position. For a given setting of the signal generator "FINE ATTENUATOR" and "COARSE ATTENUATOR," you should note that the audio signal becomes louder. If it fails to do so, it indicates that you are losing rather than obtaining gain from the 1st. audio amplifier stage. Check for a bad tube, open plate load resistor, or open coupling condenser.

This procedure can then be carried on through the set, working from the output stage toward the antenna. When checking the last i.f. amplifier stage and the detector stage, a modulated r.f. signal at the receiver's i.f. frequency is fed to the signal grid of the last i.f. amplifier tube. If the receiver seems normal at this point, the test signal can then be transferred to the grid of the preceding i.f. amplifier stage. When a signal can be obtained through one stage and not through the preceding stage (working toward the antenna), the defect has been isolated between the last two test points where the signal was injected. Check operating voltages and test component parts between these two test points until you locate the defective part.

If the i.f. amplifier section seems to be normal, check the mixer, oscillator, r.f. and antenna circuits. First, connect output of signal generator between signal grid and ground of mixer tube, with signal generator still set at the receiver's i.f. frequency. If a fairly strong signal comes through the receiver, the mixer stage is apparently operating, but the local oscillator may

not be oscillating. In this case, the conventional test is to check for d.c. voltage across the oscillator grid resistor.

In some oscillator-mixer circuits, however, no oscillator grid resistor is present. Feedback may be obtained between plate and cathode circuits or between screen grid and cathode circuits. In a case like this, a check on the local oscillator operation can be obtained by attaching the antenna to the receiver and turning the dial of the receiver to the frequency of a local broadcast station. If the local oscillator is dead, nothing will be heard through the receiver's loudspeaker.

Now, tune the signal generator to a frequency equal to the frequency of the broadcast station plus the i.f. of the set. The "FUNCTION" switch of the signal generator will be set to the "R.F. UNMOD." position. This unmodulated r.f. signal is fed to the grid of the converter tube. If you now hear the broadcast station coming through the receiver, it is almost certain that the local oscillator is not working.

You have actually substituted the oscillator of the signal generator for the local oscillator in the receiver. As an example of the proper frequency to use, if the i.f. of the set is 456 kc., and the frequency of the local station 1000 kc., then the signal generator would be set at 1456 kc. This is on Band B.

Checking a "weak" receiver: If a receiver is weak, you can get some idea where signal strength is lost by using the stage-to-stage technique just outlined for locating trouble in a dead receiver. Starting at the control grid of the output stage, set the "FINE ATTENUATOR" and "COARSE ATTENUATOR" control so that a very low output indication is obtained, or so that the signal can be barely heard. Then, as you work backwards through the set, you should note an increase in signal each time you proceed to the input of an amplifying stage. If you do not obtain an increase in output for any one stage, but find that the signal disappears or that there is a decrease, this indicates that there is a loss rather than gain in that stage.

For the accurate measurement of stage gain, a fixed amplitude input signal should be fed to the receiver from the signal generator and a tuned type signal tracer, such as the Model 33 NRI Professional Signal Tracer used to follow the signal from stage to stage.

Modulation Hum: A signal generator is often useful for checking "modulation hum" in a set. Modulation hum is recognized by the fact that hum occurs when the receiver is tuned to a station, but no hum is present when the receiver is tuned off the station. To locate where modulation hum is introduced, proceed as follows:

1. All tubes should be checked for heater to cathode leakage and grid circuits should be checked for opens. Either heater to cathode leakage or an open grid circuit might cause "hum modulation."
2. Pick up a local broadcast station with the receiver on which you hear modulation hum. Measure the a.v.c. voltage developed across the diode load resistor with modulation hum present. Now, as you check from stage to stage in the following steps, adjust the signal generator output with the FINE ATTENUATOR and COARSE ATTENUATOR controls until at least the same a.v.c. voltage is measured. This will insure that the test signal is of sufficient amplitude to cause modulation hum.
3. Feed an UNMODULATED R.F. SIGNAL into receiver, starting at the last i.f. stage and working toward the antenna. Use the proper frequency to feed through the set. For example, when checking the i.f. stages, use the i.f. of the receiver. (The receiver should be tuned so that no station is being picked up.)
4. The stage at which you first notice the hum coming through is the stage that is defective and this is where the modulation hum is being introduced. Check component parts in that stage until you locate the defective part.

Intermittent Trouble: The signal generator can be used to some extent to find the trouble in an intermittent set. It is difficult to feed from one stage to another while the intermittent is in progress, as the voltage surge due to connecting the signal generator might clear up the defect. The best way to use the signal generator on an intermittent

trouble is to make a permanent connection to the receiver and wait for the intermittent to occur.

To use the signal generator in servicing an "intermittent" set, feed a modulated r.f. signal through the receiver from the antenna. Connect the d.c. voltmeter to read the receiver's a.v.c. voltage. Note the amount of a.v.c. voltage. Turn up the set's volume control until the audio note can be heard in the speaker.

Leave the set and signal generator operating until the intermittent condition occurs. When the set goes dead, immediately check for a.v.c. voltage at the meter. If the a.v.c. voltage has not changed, the trouble is in the audio stages. If there is no a.v.c. voltage present, the trouble is in the r.f. or i.f. stages. You have thus effectively isolated the trouble to one section of the receiver.

This procedure should be carried out after the conventional "brute force" test has been made. To use the brute force test, a pair of long nose pliers is used to wiggle each part and connection in the set, looking for a particular part which will cause the intermittent condition to occur. That part is defective and should be replaced. If the defect is due to a loose connection, the connection should be resoldered.

For further information on using a signal generator in servicing, refer to your regular NRI Course.

BAND	POINTER	POINTER	POINTER
	POSITION	POSITION	POSITION
	X	Y	Z
A	197 kc.	392 kc.	516 kc.
B	622 kc.	1210 kc.	1562 kc.
C	1.9 mc.	3.68 mc.	4.75 mc.
D	5.38 mc.	10.65 mc.	14.2 mc.
E	16.7 mc.	26.1 mc.	29.4 mc.
F	34.1 mc.	53 mc.	59.7 mc.
F <sub>1</sub>	68.2 mc.	106 mc.	119.4 mc.

FIGURE 32

Correct readings for the three pointer positions indicated on the signal generator scales in Fig. 4. When the pointer is between two division lines, it is necessary to estimate its position. If your estimate is fairly close to the corresponding value given here, it can be considered satisfactory.

# **K4XL's** **BAMA**

This manual is provided **FREE OF CHARGE** from the "BoatAnchor Manual Archive" as a service to the Boatanchor community.

It was uploaded by someone who wanted to help you repair and maintain your equipment.

If you paid anyone other than BAMA for this manual, you paid someone who is making a profit from the free labor of others without asking their permission.

You may pass on copies of this manual to anyone who needs it. But do it without charge.

Thousands of files are available without charge from BAMA. Visit us at <http://bama.sbc.edu>